The background of the cover features a grayscale image of various molecular structures, including clusters of atoms and larger, more complex frameworks, rendered in a semi-transparent style.

**Physics and
Astronomy**
Annual Review
2019–20

Cover image:

The formation of carbon nanotubes and fullerenes during the process of high temperature annealing of very low density amorphous carbon. Results of atomistic simulation using machine learned GAP-20 carbon model.

Credit: Patrick Rowe

Image page 4:

The wavefunction of a large polaron is depicted on a plane of 1020 Rubrene molecules, an organic semiconducting material, with arcs of electricity giving the polaron a sense of movement between electrodes. The wavefunction was obtained from the group's in-house fragment-orbital based surface hopping technique which is capable of accurately simulating electron/hole transport dynamics for large molecular systems. VMD was used to render the image.

Credit: Matt Ellis, Samuele Giannini & Jochen Blumberger

Image page 31:

Electronic bands of two-dimensional (δ -doped) silicon measured with photoelectron spectroscopy; heavy hole (HH), light hole (LH), split off (SO) valence bands, and the two-dimensional (2D) dopant band.

Credit: Procopios Constantinou and Steven R. Schofield

Image page 45:

The star-forming region NGC6559, in the constellation Sagittarius. Red traces emission from hydrogen, the most abundant gas in the Universe.

Credit: Ian Howarth/Telescope Live

Image page 58:

The nebula IC2944, portrayed in the 'Hubble Palette'. The dark features, called 'Thackeray's globules', are dense, cold, dusty regions seen in silhouette against the glowing background gas.

Credit: Ian Howarth/Telescope Live.

Image page 63:

Artist's illustration of two merging neutron stars.

Credit: National Science Foundation/LIGO/Sonoma State University/A. Simonnet

Review edited by **Bonita Carboo**, b.carboo@ucl.ac.uk

Design © UCL Digital Media

Contents

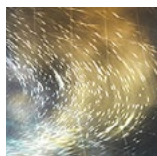
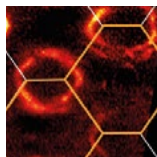
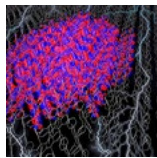
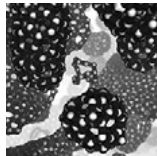

2	Welcome
4	COMMUNITY FOCUS
5	Teaching Lowdown
6	Student Accolades
7	Equality and Diversity Committee
8	Students in Action
12	Science in Action
16	Teaching Fellows
18	Outreach
23	Career Profiles
26	Alumni Matters
28	Observatory News
31	ACADEMIC SHOWCASE
32	Staff News
35	Research Degrees
36	Portrait of...
38	In Memoriam
42	A Sample of Staff Accolades
45	RESEARCH SPOTLIGHT
46	High Energy Physics (HEP)
49	Astrophysics (Astro)
52	Biological Physics (BioP)
54	Atomic, Molecular, Optical and Positron Physics (AMOPP)
56	Condensed Matter and Materials Physics (CMMP)
58	RESEARCH STATISTICS
63	STAFF SNAPSHOT

Welcome



The Covid-19 pandemic has proved to be a seismic and utterly unprecedented international crisis, which has presented our department (and UCL) with a broad and considerable range of challenges. Along with the university, our department has been largely virtual since late March 2020. The change has been difficult for all of us and I am exceptionally proud of the way staff and students have adapted to this crisis. We have come together as a community in extraordinary ways to continue our core teaching and research, while ensuring that our complex departmental systems and processes remained functional. To have achieved this at very short notice in a remote working environment is exceptional. I am glad to have the additional opportunity of this Annual Review to deeply thank all members of our department for the collegiality and professionalism they have shown. We are continuing to work hard in providing the best possible educational experiences for our students, and in producing the highest quality, rigorous research against a surreal backdrop.

Working from home in these extraordinary times, for a prolonged period, has not suited everyone in the department. Some staff and students have been facing disproportionately heavy burdens depending on their environment and circumstances. One positive however has been that many more of us have become mindful that the idea of common core working hours

needs to be carefully re-framed as some people will have no option but to work at odd times (particularly as nurseries and schools are largely closed). Flexibility and understanding of differences in working times and carer responsibilities has been vital at this extraordinary time, and we will need to continue to play our part to help each other.

Going forward, in 2020/21, and at the time of writing, we are restarting research lab activity with a partial (25% occupancy) reopening of our buildings, but with those who can work from home continuing to do so. The priority for a considerable time will be to ensure all appropriate measures are in place to keep staff and students as safe as possible. Enormous efforts have also been made across the department to plan for blended teaching in UG and PGT, that combines remote teaching, some face-to face delivery (e.g. in labs) and additional pastoral support. We've reached an important milestone with the confirmation of the assessments and exams for this year. Thanks to the hard work of so many colleagues, we had robust executed plans in place for a full programme of remote examinations in June 2020, and adhered to UCL's 'no detriment' policy that ensures no student's long-term future will be negatively affected by the circumstances in which they have sat their assessments. I am enormously grateful to all in our department who have worked at speed to review examination plans

and adapted them for circumstances created by the pandemic. This work has given us the very solid foundations to plan the 2020/21 assessments, which are also now likely to be conducted remotely.

It is quite clear that post-Covid will not be the same as pre-Covid, and our research activities will need to adapt to flat-cash settlements for exploitation grants and a likely lack of resources for new projects. We will need a new agility with funding and look for the opportunities. Meanwhile, of course, EU exit is still happening and we look to UKRI for the pathway that will ensure UK remains a key global player in physics and astrophysics. There are also challenges in ensuring vitality and future proofing of technology through active R&D. Nevertheless, as you will read from the outstanding research highlights in this Review, our department is well placed to adapt and there are many reasons to be positive. We continue to attract outstanding talent through new lectureship appointments (Drs Edina Rosa, Stephen Feeney, Mihkel Kama, and Jason Sanders being the latest in 2020), and via Royal Society, STFC and UKRI Future Leader Fellowships. Going forward, we are strongly placed to deliver on the new European Strategy for Particle Physics, including the priority full exploitation of LHC and its High-Luminosity upgrades of accelerators and experiments. We are positioning for the major upgrade of the Diamond Light Source (2024/5), along with those of ATLAS and DUNE. The Dark Energy Spectroscopic Instrument (DESI), the construction of which UCL has had an important role, is now producing high quality images through its wide field corrector lens system. Recently announced successes in the STFC/EPSC Quantum Technologies for Fundamental Physics (QTFP) have opened new chapters in novel and very interdisciplinary science that will involve an exciting new close collaboration between the department's HEP and AMOPP groups in particular.

This year has also been one of deeper reflection, in various fora and discussion groups across the department, inspired by the Black Lives Matter movement and the hugely detrimental impact of systemic and institutional racism. The Department of Physics and Astronomy is committed to equality, diversity and inclusion. I take pride in the fact that our department is so greatly enriched by its diverse and international community. We strive to create

an environment in which everyone feels able to participate to their full potential and are valued for their contributions. All avenues of work in this department are stronger when they derive from a community grounded in respect and diversity. I believe that creating this positive and inclusive work environment is a responsibility shared by all the members of our department, and we all have a role in breaking down the inequalities that are present because of differences in race, ethnicity, nationality, gender, sexuality, religious belief, disabilities, caring responsibilities and all protected characteristics. I recognise that we must not be complacent and there is still considerable progress to be made. The challenge of attracting more Black students and staff into pursuing physics and astrophysics in this department is an enormous and complex example, but not without solutions. Many Black students at school perceive other university degree subjects are more supportive and rewarding, resulting in a loss of talent to physics and astrophysics. The challenge and opportunity for us to discuss, debate and act on is how we can take advantage of the early school interests shown by Black students for physics and nurture this interest, engage in their burgeoning science aspirations, and support their learning.

The relatively few Black undergraduate and postgraduate students that do elect to study in our department must, as indeed should all students, experience lecturers, mentors, tutors, staff and peer interactions that give them a strong sense of belonging. We cannot, and must not, accept any factors that negatively impact on students' sense of belonging in our department, and we must guard against unconscious bias, microaggressions and stereotype threat. Through the department's student societies, PDRA network, listening groups, EDI committees and – above all – its individual members, we should aim to continually communicate values of respect and inclusion through our actions, physical environment, degree education content, and work to eradicate acts motivated by bias and racism.

Working together we will emerge stronger from the several challenges ahead and with the foundations to ensure our quick recovery to normality (or full adaptation to the 'new normal').

Professor Raman Prinja
Head of Department

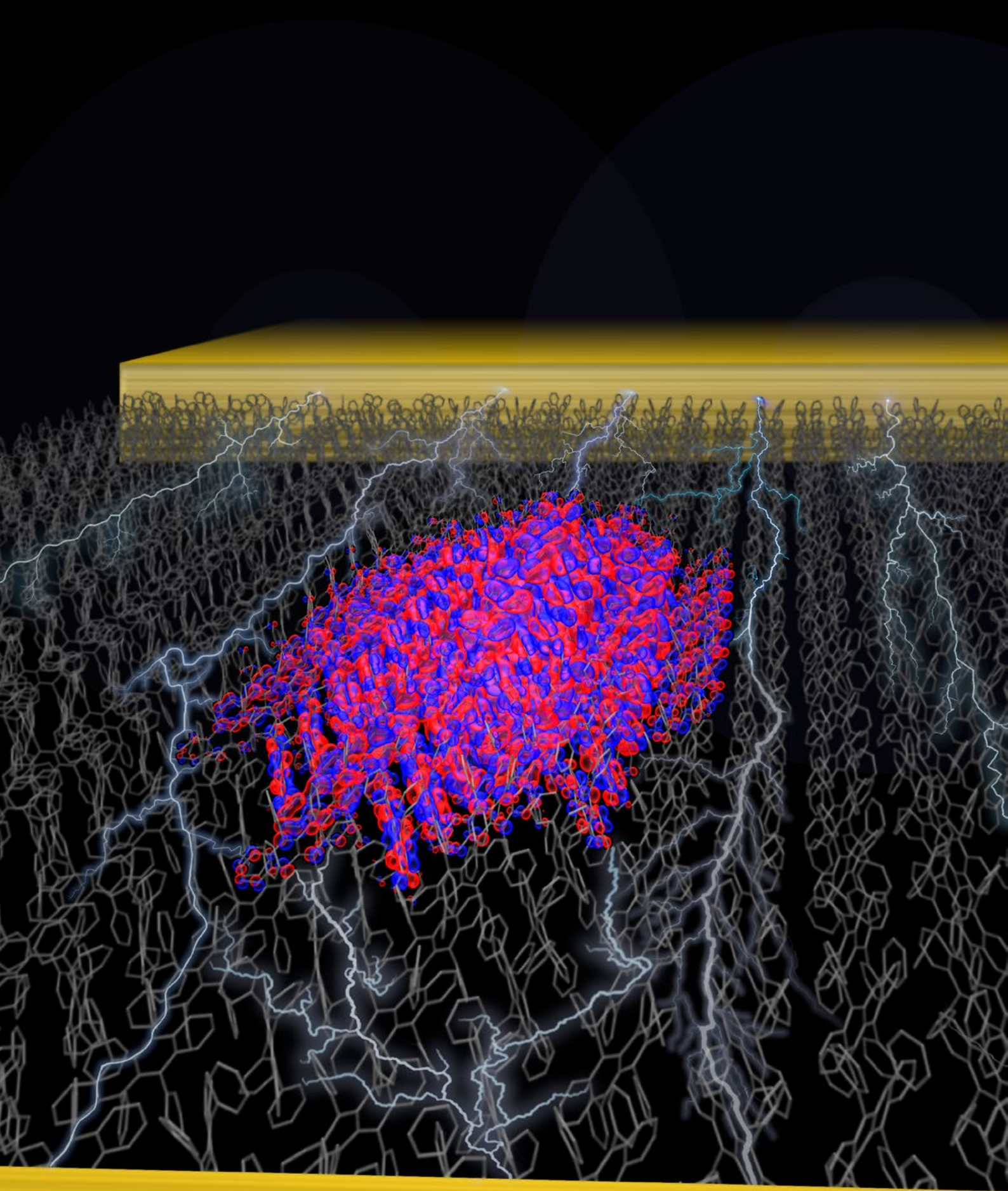

Community Focus

Teaching Lowdown

Teaching in the Physics and Astronomy Department

This has been a particularly challenging session: from mid-March, all of our face-to-face teaching and assessment has been replaced by online remote activities. Many thanks to all our students and staff for their hard work, flexibility and patience as we have adjusted to the rapidly changing situation and requirements. Among the teaching highlights this year, ten undergraduate students from the Department (Pietro Anselmetti, Jackson Barr, Jiaye Ding, Kumail Arif Sultan Kermalli, Hasan Sayginel, Lodovico Scarpa, Marion Thomas, Kalid Ulas, Scott Woolnough and Jaime Ruiz Zapatero) were placed on the Dean’s list, which commends outstanding academic performance by graduating students, equivalent to the top 5% of student achievement. In these exceptional circumstances, our student representatives have played a key role in communicating requests and concerns and maintaining a sense of community. We are therefore truly delighted that Danny Gold was named Academic Rep of the Year in this year’s UCL Education

Awards, and that Espen Bergqvist and Manasvee Saraf were shortlisted. Congratulations also to our Education Support Team of Selina Lovell, Helen Copeland, Ryan Edmonds, Sadia Begum, Annalisa Medici, and Nadia Waller and to Stan Zochowski, who received team Faculty Educations Awards and to the following staff for their well-deserved senior promotions: Paul Bartlett (Professorial Teaching Fellow), Daven Armoogum (Principal Teaching Fellow), Elinor Ashgrove (Principal Teaching Fellow), Nick Nicolaou (Principal Teaching Fellow) and Jasvir Bhamrah (Senior Teaching Fellow). Finally, we note with pleasure that before the current restrictions came into effect, the Department held its first highly successful “PandA Day” Physics & Astronomy Festival. This very popular and well-received event showcased the wide range of outstanding talent and skill within the Department. We very much hope that we can continue the series in the not too distant future.

Professor Neal Skipper
Director of Teaching

Intake

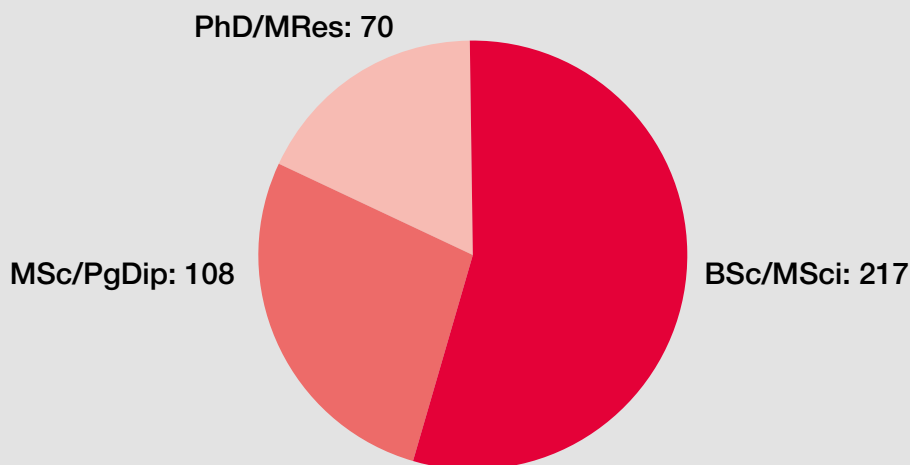

Awards

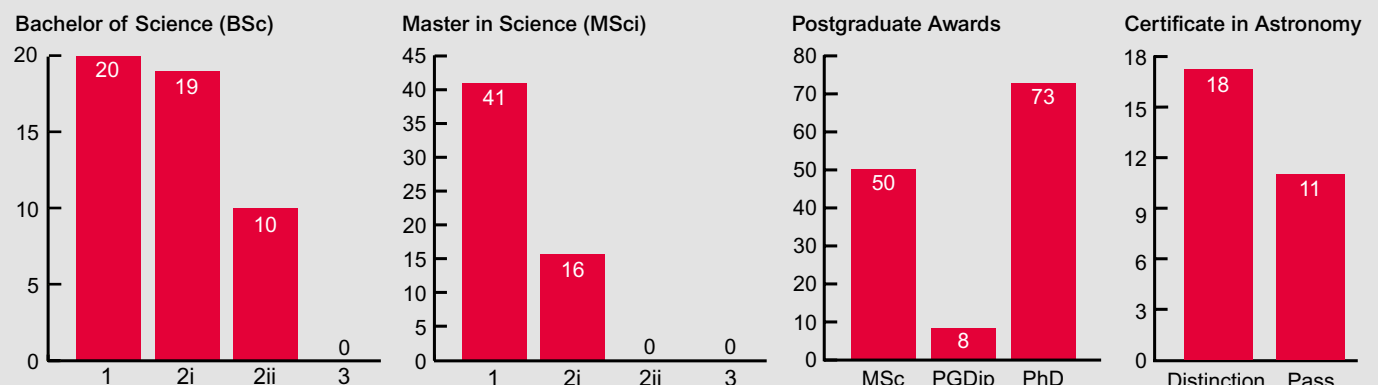

Student Accolades 2018–19

Undergraduate Prizes

Oliver Lodge Prize

Best performance 1st year Physics

Mr Zhu Sun

Halley Prize

Best performance 1st year Astrophysics

Mr Omar Choudhry

C.A.R. Tayler Prize

Best performance in Comm. Skills, based on 1st+2nd year

Mr Dominik Kufel

Wood Prize

Best performance 2nd year Physics

Mr Ke Ma

Huggins Prize

Best performance 2nd year Astrophysics

Mr Ryan Brady

David Ponter Prize

Most improved performance 1st to 2nd year

Ms Cecilia Kalien

Sydney Corrigan Prize

Best performance in experimental 2nd year work – PHAS0028

Ms Lijin Feng

Best Performance Prize

Third year Physics

Mr Alexander Nagen

Best Performance Prize

Third year Astrophysics

Ms Manasvee Saraf

Additional Sessional Prize for Merit

Best 4th year Physics project achieving a balance between theoretical and practical Physics

Mr Felix-Ekkehard Von Horstig

Burhop Prize

Best performance 4th year Physics

Mr Matthew Rayment

Herschel Prize

Best performance 4th year Astrophysics

Mr Casey Cragg

Brian Duff Memorial Prize

Best 4th year project

Mr Abel Beregi

William Bragg Prize

Best overall undergraduate

Mr Andrei Barbuta

Tessella Prize for Software

Best use of software in final year (Astro) Physics project

Mr Nickolay Walters

Postgraduate Prizes

Harrie Massey Prize

Best overall MSc student (jointly awarded)

Mr Samuel Lai MSc Astrophysics

Mr Isaac Squires MSc Physics

High Energy Physics Prize

Outstanding postgraduate research in High Energy Physics

Dr Ferghus Keeble

Carey Foster Prize

Outstanding postgraduate research in Atomic, Molecular, Optical and Positron Physics

Dr Cameron Deans

Marshall Stoneham Prize

Outstanding postgraduate research in AMOPP (Jointly awarded)

Dr Marios Hadjimichael

Dr Martin Fitzner

Jon Darius Memorial Prize

Outstanding postgraduate physics research in Astrophysics

Dr Felix Priestley

Biological Physics Prize

Outstanding postgraduate physics research in Biological Physics

Dr Adrian Hodel

Chris Skinner Prize

Outstanding postgraduate research in Astrophysics

Dr Arianna Sorba



Physics and Astronomy prize winners 2018/19, with Neal Skipper, Raman Prinja and Lori Coletti Campbell

Equality & Diversity Committee

What have Athena SWAN and project Juno done for us?

Athena SWAN (Scientific Women's Academic Network) is a charter award scheme launched at the Institute of Physics in London in 2005 by ECU (Equality Challenge Unit) as a continuation of the original Athena project which was setup in 1999 by scientific women in the academia for scientific women in the academia, its aim was to advance the progress of women's career in Science, Technology, Engineering, Maths and later Medicine was included (STEMM). The need for such a scheme was due to the underrepresentation of female students and academic staff within the STEMM disciplines.

In 2015 Athena SWAN scheme was expanded to include all academic disciplines and include professional and support staff, also gender equality was more broadly considered. Today Athena SWAN scheme exists in the UK, Ireland, Australia, Canada and the USA with three award levels: Bronze, Silver and Gold. Our department holds the Silver department award and UCL holds the Silver institution award.

Project Juno is another award scheme established in 2007 at the Institute of Physics by physicists for physicists in response to the need to attract more women in physics. It currently runs in the UK and Ireland with four award levels: Supporter, Practitioner, Champion and Excellence Award. Our department holds the Champion award. Juno and Athena SWAN awards are reciprocal, one achieved award can be converted to the other. In April 2019 our department has successfully converted the Juno Champion award to Athena SWAN Silver award. Both awards have time limit of four years to ensure that actions for positive change are continuous and changes are sustainable. Our Juno Champion award was successfully renewed in February 2019.

Both of Athena SWAN and project Juno have played important roles in shaping the department infrastructure by embedding their equality, diversity and inclusion principles throughout the practices and commitments of the department, that involves rigorous work of self assessment to identify and remove any barriers or challenges that prevent staff and students from achieving their full potential, and to create inclusive culture that benefits everyone.



Rafid Jawad presented with the Department's Athena SWAN Silver certificate by Alison Johns, Chief Executive of Advance HE

Taking part in these award schemes has brought many positive changes in the department including the achievement of excellent gender balance of academic staff, the support of career development, the support of flexible working and the active engagement in bullying and harassment prevention. Committees and networks have been established and supported by the department including Equality and Diversity committee, Welfare committee, PhD and Research associates Network, Women's Lunch and Undergraduate Women in Physics Society.

Achieving these awards means we all have much work to do in sustaining the positive changes, implementing the action plans for overcoming any identified challenges and maintaining commitments to equality, diversity and inclusion to make the department a better place for everyone.

Rafid Jawad

Technical support staff member of the E&D committee

Students in Action

Women in Physics group

The Women in Physics group (WiPg) at UCL has been championing and celebrating women and their achievements through talks, lunches and lectures. Further to this we have provided a platform and events to support intersectionality aspects to all genders. In recent years this took place under the guidance and leadership of Dr. Lia Li and Prof. Dorothy Duffy, who did an outstanding job. On 6th of November 2019, the two retired from their positions on heading the group and handed over to Abbie C. Bray (AMOPP PhD student) and Prof. Carla Faria. It was clear we had big shoes to fill! We would like to thank Dorothy and Lia for the opportunity and all their hard work over the years. The first event organised, was with Dr Sofia Qvarfort and her talk on *A VIP in Physics*. She discussed her journey through academia with a visual impairment. The talk was both lively and informative, showing the pitfalls institutions have in supporting people with specific needs as well as a debunking of stereotypes.

We have also been making connections with various other diversity groups across the country in order to hold future large-scale events – including the British Federation of Women Graduates. The WiPg also does behind the scenes work, whether it is participating at departmental open days, writing short pieces for prospective students, being invited to meet with the Equality and Diversity Committee – the group wants to make effective change and support others.

As February ended, more events were being finalised and then the pandemic hit... As the world turned more virtual, it was time for WiPg to adapt. The first voyage into this world was a twitter take over with Lucy Hogarth (UCL Astrophysics PhD student), the aim was to support autism awareness week from the female perspective.

Autism Awareness week was 30th March – 5th April, and over the week Lucy provided two sessions. The first, was an explanation on how female autism differs from male autism. The next, Lucy provided excellent posters with my running commentary. Both events got positive feedback, sparked conversations and provided a learning experience!

Feel free to check it out on Twitter at: [@AbbieBrayPhys](https://twitter.com/AbbieBrayPhys)

The next journey into the virtual, ties in with the *Quantum Battles in Attoscience* conference held on 1st – 3rd of July 2020.

The conference has attempted to widen participation by utilising the advantage of its new virtual nature. This has opened discussions about what more can be done to be more inclusive in the future, both virtually and physically. The effort in diversifying contributors has been a struggle due to Covid-19 constraints but Prof. Carla Faria and her brilliant team have worked hard to ensure everyone has had an opportunity for their voice to be heard!

The world is changing more quickly every day, and sometimes it is worth celebrating achievements of individuals to spur on the long fight we still have ahead for

equality. In February, Dr Gillian Peach sent WiPg an article from a 1986 edition of *The Bulletin*, this highlights that women have campaigned for equality at UCL for 30+ years. Although pioneering, this shows that change has taken a long time and we are responsible to continue their legacy for all minorities and diversities, not just women. Right now, it has never been so important to do so – the WiPg would like to make it clear that we stand with Black Lives Matter. We must encourage, support and listen to all our colleagues to make effective change. If you have any ideas for an event (virtual or not), please feel free to contact me: a.bray@ucl.ac.uk

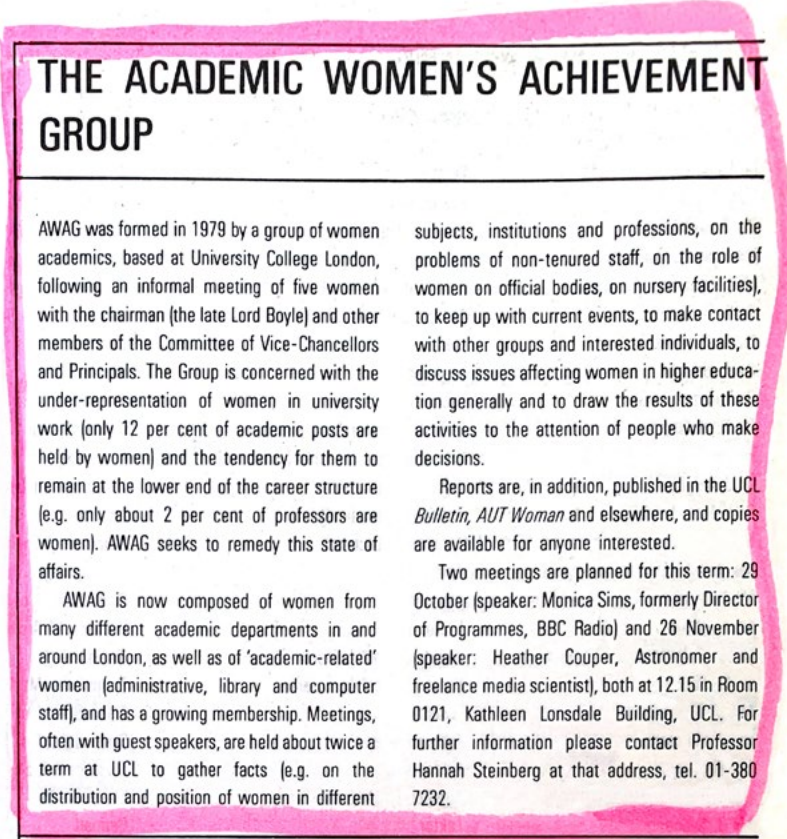

Stay safe and be kind
Abbie C. Bray

Event Horizon

The Physics Society committee would like to thank all of our members for their continued interest in our various events. We would also like to give a special thanks to the department for all their support.

It has been a great and enjoyable year – below are just some of the highlights of what we have achieved in the past few months!



2019/2020 Committee.

Left to right front row: Dhruv Mitesh Kotecha, Rania Shafiq, Juan Jose Juan. Left to right second row: Iman Sanai, Jaya Chand, Arti Vasanthakumaran, Karina Dansinghani. Left to right third row: Gustavs Zilgalvis, Shahzad Sanjrani, Lara Amusan. Left to right back row: Ewan Miles, Filippo Bounous, Nicolas Kourkoulas.

Fresher's Week

We started off the year strong with a range of events including a tour of central London, an English Breakfast and a movie night. Though the showstopper for the half-term was our fifth annual Kick-Off, which not only yielded a great turnout but introduced Freshers to their course mates as well as their new campus.

Spectrum Lectures

It was an honour to host such a prestigious selection of guest lecturers for our Spectrum series. From focusing on inviting speakers that will appeal to Freshers but also engage higher year students, we again achieved high turnouts and thoroughly enjoyed learning about the new research and developments in the field of Physics. This included lectures from CEO of Faculty Dr Marc Warner, to British Cosmologist Lord Martin John Rees.

Winter Ball and Boat Party

Our much-awaited social events of the year were a great success with students unwinding and having fun at our annual Winter Ball in November, in collaboration with the UCL Maths Society. Our Boat Party in early March was also one of our biggest social events as we relaxed and enjoyed an evening cruise down the River Thames.

Joint Undergraduate Research Conference

Our fifth annual joint conference with Imperial College London and Queen Mary University of London took place in January this year. On the theme of Cosmology and Exoplanets: Both Sides of the Nobel Prize, we invited PhD students from all three universities to give talks on their research, followed by an informal social.

Wellbeing Event and Welfare Officer

We were proud to launch our first ever Wellbeing event, hosted by us in collaboration with the Physics and Astronomy Department. It was due to be on the topic of exam stress, spending the afternoon in a relaxed setting, learning and having a discussion on this topic, as well as giving some helpful advice on how to combat exam stress. Unfortunately, a physical meeting did not take place (due to the early close of campus in March), but all resources for the event were posted on our society website. We hope that this is only the start of a series of social meetings we will hold centered around mental health and wellbeing.

We are also proud to announce that a new role of Welfare Officer will be introduced to the committee for the 2020 academic year. We feel like this role will be important in not only helping to direct the wellbeing meetings, but to also be a point of contact for someone to talk to at our social events.

On behalf of the committee it has been an absolute pleasure to serve our members, for it was them that made our events great and all the work put in behind the scenes worth it. We would also like to wish the new committee the best of luck, we are so excited to see how they will take the society forward in the coming academic year.

Lara Amusan

IT Officer on behalf of the 2019/2020 committee

The Postgraduate Physics Society

The key to a successful PhD is balancing work and play. For many students, however, the latter is often overshadowed by constant meetings, deadlines, and broken code. Normally, most students would not have the opportunity to meet people from other research groups. The goal of the student-run Postgraduate Physics society (PGPS) is to provide opportunities for students across all sub-departments in physics to meet, share ideas, and have fun over pizza and refreshments.

Throughout the academic year, the PGPS hosts monthly 'PhD Talks', where UCL students are invited to give a short 20-minute presentation about their research topic. This year, we also had talks from recent graduates about their PhD and working experience. These events provide a relaxed setting where a student working on planet formation can learn about particle physics detectors, exoplanets and vice versa.

The PhD talks series aside, we also hosted a pub quiz, where the students got a chance to show off their general knowledge. The quizzes are usually very well-attended and seem to be a favourite amongst the students.

Coronavirus halted our plans for another quiz and a hackathon during the summer. Despite that, the PGPS hosted a virtual Mathematical and Physical Sciences (MAPS) faculty heat of the UCL 3 Minute Thesis competition.

We had contestants from Physics & Astronomy, Chemistry, Space and Climate Physics (MSSL) and Statistical Science. The event was successful with audience members from almost every department in MAPS, and the finalists from the faculty heat moved forwards to the general UCL 3MT competition shortly after. The winner from the Mathematical & Physical Sciences was Faiza Javaid from the Department of Chemistry with antibody-drug conjugates: the quest for a magic bullet in the war against cancer and the runner-up was Catarina Alves from the Department of Physics and Astronomy with Classifying far explosions in the Universe.

All things considered, the year started greatly and become more challenging for the Postgraduate Physics Society. We're continuously maintaining and improving the wonderful community that's been built in Physics & Astronomy, and looking forward to continuing this next year!

All things considered, it's been another great year for the Postgraduate Physics Society. We're continuously maintaining and improving the wonderful community that's been built in Physics & Astronomy, and go on doing so in the year to come!

Catarina Alves and Johannes Heyl
on behalf of the
Postgraduate Physics Society



Christmas Pub Quiz



Catarina Alves



Faiza Javaid

Headline Research

Experiments with atoms and molecules in high Rydberg states – from cold chemistry to quantum information processing

The experiments performed in Prof Stephen Hogan's laboratory in the AMOPP group are centred around studies of atoms and molecules with one electron excited to a state with a high principal quantum number n . These high- n excited states are known as a Rydberg states and many of their properties depend strongly on the value of n . For $n > 55$, the sizes of these excited atoms – as determined by the spatial extent of the charge distribution of the excited electron – exceed 500 nm; they can possess electric dipole moments larger than 10000 D; and they have lifetimes > 1 ms. Because of these extreme properties Rydberg atoms and molecules are of interest in a wide range of research areas – from cold chemistry to quantum information processing.

In the last year researchers in Hogan's group have reported major advances in a range of experiments with helium atoms and nitric oxide (NO) molecules in Rydberg states. They have performed the first experiments to study the resonant transfer of energy [Fig. 1(a)] in collisions of Rydberg atoms with polar ground-state molecules at temperatures close to 1 K [1].

These results are of importance for studies of chemical processes that occur at low temperature and in which long-range interparticle interactions play a key role. Hogan's group also trapped cold Rydberg NO molecules for the first time. These experiments were performed in a cryogenically cooled electrostatic trap [Fig. 1(b)] and permitted the observation of effects of blackbody radiation and intramolecular interactions on the decay of the molecules on timescales up to 1 ms [2].

In addition to this Hogan's group have recently developed and experimentally demonstrated a method to perform matter-wave interferometry with atoms in Rydberg states [Fig. 1(c)] by exploiting forces exerted on them using inhomogeneous electric fields [3]. The excited atoms used in these experiments had dimensions of ~ 500 nm and are some of the largest objects for which matter-wave interference has ever been observed. The experimental techniques developed in this work are of interest for quantum sensing, and measurements of the acceleration of antimatter, in particular positronium atoms, in the gravitational field of the Earth.

Hogan's group also works on the realisation of hybrid approaches to quantum information processing with gas-phase Rydberg atoms and superconducting microwave circuits. In this setting the atoms are foreseen to act as long-coherence-time quantum memories, or a medium in which optical photons, used for long-distance quantum communication, are converted to microwave-photons for quantum computation. In the last year Hogan's group performed the first experiments to demonstrate a coherent interface between atoms in Rydberg states and microwave fields in a two-dimensional superconducting microwave resonator fabricated on a niobium nitride chip [Fig. 1(d)] and operated at 4 K [4]. These results represent a major breakthrough in the development of hybrid quantum processors composed of Rydberg atoms and superconducting circuits.

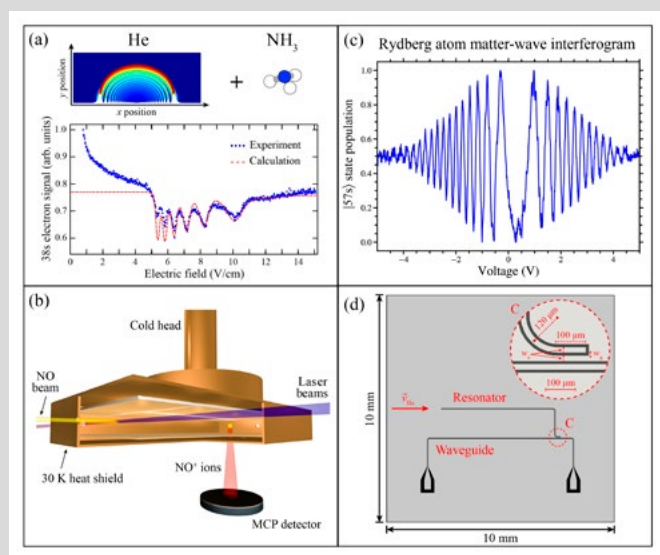

Figure 1 (a) Electric-field-controlled resonant energy transfer in cold collisions of Rydberg He atoms with ground state NH₃. (b) Apparatus for deceleration and electrostatic trapping cold Rydberg NO molecules. (c) Matter-wave interference fringes observed for helium Rydberg atoms. (d) Diagram of a niobium nitride superconducting chip used to realise a hybrid interface between helium Rydberg atoms and superconducting circuits.

[1] K. Gawlas and S. D. Hogan, "Rydberg-state-resolved resonant energy transfer in cold electric-field-controlled intrabeam collisions of NH₃ with Rydberg He atoms", *J. Phys. Chem. Lett.* 11, 83 (2020)

[2] A. Deller, M. H. Rayment, and S. D. Hogan, "Slow decay processes of electrostatically trapped Rydberg NO molecules", *Phys. Rev. Lett.* In Press (2020)

[3] J. E. Palmer and S. D. Hogan, "Electric Rydberg-atom interferometry", *Phys. Rev. Lett.* 122, 250404 (2019)

[4] A. A. Morgan and S. D. Hogan, "Coupling Rydberg atoms to microwave fields in a superconducting coplanar waveguide resonator", *Phys. Rev. Lett.* 124, 193604 (2020)

Science in Action

Panda Day Review

On the 21st of January 2020, the first Panda day was held in Logan Hall UCL. Panda day is the Physics and Astronomy department’s way of showcasing the diverse range of talents from our staff and students. The idea for the day was inspired by undergraduate Cumberland Lodge visits and the creativity shown by students there. But we wanted to extend this idea and incorporate elements of an arts and entertainment festival.

The day itself was incredibly successful. We had classically trained singers to rock musicians to stand-up comedians, from budding actors to artists! There was a main stage, an area of stalls which provided science arts and crafts, interactive experiments and even a physics meme gallery all set in a fun and inclusive manner. The meme gallery made for hot competition where an amazon voucher was up for grabs to whichever submission had the most votes.

A series of talks were performed throughout the day highlighting the science in everyday things. James Marsden did an excellent job explaining how “Magic the Gathering” is Turing complete. Later on, Dr Sofia Qvarfort took us on a fun exploration of philosophy and causality in physics.

Like most Cumberland Lodge trips, a “Physics Play” was organised which was a lively hybrid of Shakespeare and everyday life in the department... Saad Shaikh did the most inspiring performance of Raman with a wonderful parodied soliloquy from Hamlet (adapted by Alex Nico-Katz).

We had everyone from first years to the Head of Department enjoying every ounce of the festival, including friends of friends and members of the public too!! We would like to thank everyone who attended, took part and organised this stellar event.

So, if you feel you have missed out – do not worry! We will be back next year with a new Panda Day and we have plans for it to be even bigger and better, even if it might be virtual! Want to put your name on the list to take part next year? Email us! panda@live.ucl.ac.uk

See you next year,
Panda Committee



Undergraduate James Marsden gives his talk on “Magic the Gathering” is Turing complete.



PhD student and rockstar, Saad Shaikh, raising the roof!



Prof. Sergey Yurchenko performs “Toss a coin to your lecturer” with cast of the Physics play.

Welfare and Wellbeing Event

The department Welfare Committee organised the first Welfare and Wellbeing event for both staff and students on Friday 24th January 2020. The session highlighted the hard work that is being done by both the Student Support and Wellbeing and the Workplace Health Staff Wellbeing teams in supporting and assisting the Physics and Astronomy community in accessing help and support if needed.

Thank you to all of you that attended the event. The event was informative, enjoyable and interactive. The therapy dogs were a huge hit and very well behaved. We had three dogs in attendance, Clemmie, Flo and Bella.



Therapy dogs session with Clemmie, Flo and Bella

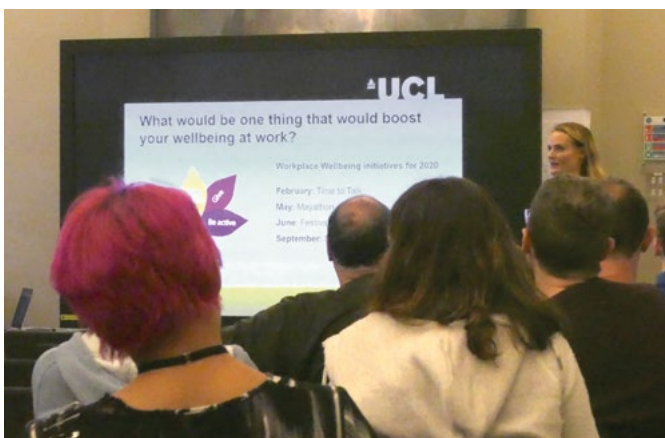

Kristina Middleton, UCL's Workplace Wellbeing Coordinator gives a talk on Staff Wellbeing.

X-ray imaging of human chromosomes

The X-ray ptychography method involves scanning a coherent X-ray beam over a sample and collected the diffracted X-rays on a sensitive detector. The relative phases of the diffracted X-rays are lost, but can be recovered using self-consistency from overlapping areas of the sample. Dr. Darren Batey has implemented this ptychography scheme at the Diamond Light Source synchrotron, which produces sufficiently coherent X-rays. The phase contrast images are highly quantitative and allow accurate mass determinations of the sample on an absolute scale. UCL PhD student Archana Bhartiya applied this method to image human chromosomes. A typical example, shown in Fig X, has allowed a determination of the masses of each individual chromosome in the metaphase state of the cell cycle. The expected amount of DNA from the human genome sequence, combined with the known associated proteins, shows discrepancies in some places. This is believed to be due to the presence of satellite DNA in so-called "heterochromatic" regions of the genome.

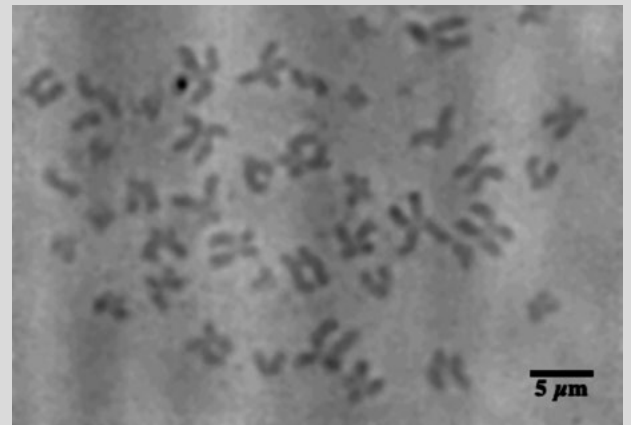

X-ray ptychography image of human chromosomes measured at the Diamond Light Source.

ORBYTS

2019 was another year of impact and expansion for UCL and MSSL's ground-breaking Original Research By Young Twinkle Scientists (ORBYTS) program. ORBYTS offers secondary school pupils the opportunity to get involved in cutting-edge space research. We do this by partnering PhD student and post-doctoral researchers with secondary schools where they facilitate and inspire the school students involvement in science research. The researcher visits the school fortnightly throughout the year. While this supports the research projects, we have found that one of the greatest benefits that school students report is simply the opportunity to get to know who scientists are and authentically experience what scientists do. We have seen that this is actively dispelling harmful stereotypes and helping to humanise science, making it more accessible and inclusive for all. The programme is particularly trying to work with students from under-represented groups in science, where this can play an important role in addressing the chronic diversity issues that face science through relatable science role models.

Since 2016, we have expanded to 24 researcher-school partnerships, involving over 200 pupils last year. The programme has now enabled more than 80 school students to become authors on published scientific papers, inspiring a new generation of scientists. Particularly we have seen the number of students choosing to take STEM subjects at A-level and University increase in the schools that we partner with.

ORBYTS starts with a launch event at UCL, in which the students visit the University and hear talks from some of UCL's world-leading experts. The researcher then visits the school regularly for 6 months. With the expansion of the programme this year, the range of research topics

undertaken by the schools has further diversified. This year projects involved school students in: organising their own exoplanet observations (thanks to observation time provided by the Faulkes Telescope Network) then analysing these observations with UCL's exoplanet tools, studying the spectra of star forming regions, analysing the explosions of massive stars, producing spectral line lists with the ExoMol group, studying bright auroral flares in the Northern lights of Jupiter, analysing the space environment around Earth using a fleet of ESA and NASA spacecraft, applying artificial intelligence techniques to planetary surfaces and galaxies, and studying the impact of space science on society in partnership with UCL's Science and Technology Studies group. At the end of the project, the students visit UCL to present their research at an ORBYTS conference. Photos from the 2019 conference are shown below. We are still trying to identify a lockdown solution for this for 2020.

The profound impact of the programme would not be possible without the hard work, passion and talent of our fantastic PhD students and Post-doctoral researcher. From one school every student involved reported the whole experience as "life-changing". ORBYTS student Alena this year said of the ORBYTS project she was involved in: "What we did in ORBYTS really changed my view on science. I never thought Physics could be something I could do. Just being part of it showed me more possibilities of science I'd never even thought of and sparked interest in other parts of science which I will never forget."

William Dunn (coordinator of the programme) very much welcomes contact from any researchers or schools interested in taking part.



A selection of images taken from the end of year 2019 ORBYTS conference, where schools present their research findings to their fellow ORBYTS pupils and partnered researchers in a UCL lecture theatre. Schools that could not attend sent a video clip for everyone to watch, however being part of and delivering to an live audience allowed everyone to interact with the huge variety of projects, pupils and schools taking part in a most enjoyable and fascinating evening.

Rocket Launch in Svalbard

After 16 weeks of Covid-19 lockdown, it is difficult to imagine that last winter I was in Svalbard for a NASA rocket campaign. I am Dr Anasuya Aruliah (Astrophysics Group). With electro-optical engineer, Dr Ian McWhirter, we run a network of five Fabry-Perot Interferometers (FPIs) in Arctic Scandinavia.

Svalbard is close to the magnetic north pole, so we see dynamic auroral displays, caused by the interaction between the solar wind and Earth's magnetic field. Many countries bring their instruments here, not just for space weather, but also for monitoring Arctic environmental experiments. Our FPIs monitor the winds and temperatures of the top layer of the Earth's atmosphere. Low Earth Orbiting Satellites skim through this layer, as does the International Space Station.

In October 2020 we went to prepare our FPIs to support three NASA rocket experiments: CREX-2, CHI, and ICI-5. We waited for perfect launch conditions from the early hours, for two and a half weeks. We monitored the FPIs from the warmth of our office, while camera teams waited on the mountain outside the Kjell Henriksen Observatory and a remote research station at Ny Alesund. Temperatures dropped dangerously to minus 48°C, with high winds.

There was an additional risk. The teams needed to watch out for polar bears. A third camera team flew over the sea to the west of Svalbard. Together they triangulated puffs of Barium and Strontium released by the rockets, which were then caught in the winds caused by ions and neutral gases, respectively. The aim is the study of electrodynamics of the magnetic cusp.

There is a YouTube video of the releases:

<https://www.youtube.com/watch?v=CACmRLRuU3o>

Two of the three rockets were launched, but the weather and solar conditions were not good enough for the launch of CREX-2. We anticipated another attempt in November 2020, but the coronavirus lockdown occurred. We wait in hope for a 2021 launch, when we start to come out of solar minimum, and better launch conditions.

The ICI-5 launch can be seen on YouTube here:

<https://www.youtube.com/watch?v=gZgfbE-8lb8>

and the CHI rocket launch is here:

<https://www.youtube.com/watch?v=oOGvE8m61T4>



View of aurora over the Kjell Henriksen Observatory, Svalbard.

Credit: Dr Mikko Syrjäsuo at the Kjell Henriksen Observatory



Puffs of Barium and Strontium released by the NASA CHI rocket on 10 December 2019, as part of the international Grand Challenge Initiative for the Cusp.

Credit: Dr Mikko Syrjäsuo at the Kjell Henriksen Observatory

Teaching Fellows

Clearly, this has been quite a year for the Department. Covid-19 dominates every activity and that includes the work of the Teaching Fellows. But we can squeeze some good news from this situation. The Teaching Fellows have been at the cutting edge of physics education at UCL. We have been active in pedagogy at Departmental, College and national level for quite a few years now. This has been critical in this pandemic era as we have had to change how we look after our students, how and where we teach them, and use this time as a means to innovate for the benefit of all. This has resulted in significant changes in all aspects of our delivery with the introduction of new ways of teaching, pastoral support and learning (using advanced IT solutions) that were not even thought possible a few years ago.

The sort of things that will be on offer are remote 'labs' in the Bloomsbury and Observatory centres that include 3D tours, with remote demonstrated led experiments, remote 'home labs' and new interaction activities in computing courses. All of this will be underpinned by the increase in funding we have received to put all of this into place. In addition, there are some practical courses that take place in the Department with the usual 'social distancing'. The planning has not been easy, but it is worth it.

The Teaching Fellows team has also acted in advisory roles on many Departmental, Faculty and College panels that seek to find the optimum path through Covid 19 and beyond. Our best practice and knowledge is spreading through UCL as never before!

Paul Bartlett
Principal Teaching Fellow

New collaborative initiatives in educational research in the Physical Sciences

The launch of the New Collaborative Initiatives in Educational Research in the Physical Sciences network took place in September 2019, funded by a Researcher-Led Initiative Award. Aiming to link educational researchers across London to promote new collaborative research, this one-day event attracted attendees from the Physical Sciences throughout London, the University of East Anglia and from as far as the University of Aberystwyth.



With a lack of strong, welcoming, local networks linking early career researchers with those more experienced in the field, the project aims to enable early career researchers to access experience, funds and knowledge to facilitate efforts in the improvement of teaching and learning for students.



Prof Michael Reiss

Prof Michael Reiss, Professor of Science Education at UCL, delivered an enthusiastically received workshop discussing research methods to improve one's teaching in the sciences, including qualitative and quantitative methods, longitudinal studies and surveys, how to choose journals in which to publish and essential factors to consider in the publication process.



Dr Stephen Potts

Our showcase of educational research at UCL included research by teaching fellows from both the Department of Physics and Astronomy and from the Department of Chemistry. Stephen Potts, Senior Teaching Fellow in the Department of Chemistry at UCL and winner of a 2020 Provost Education Award, spoke about his research in easing the student transition to higher education. Stephen has used a pre-university Moodle page with welcoming videos, virtual tours, revision materials and more to reduce the anxiety students feel and increase their confidence, preparing them to cope better with their transition into higher education.

Anna Roffey, also a Senior Teaching Fellow in the Department of Chemistry at UCL, followed with her research on peer assessment at undergraduate and taught postgraduate levels which aimed to increase active learning and critical analysis skills. At first year level, peer assessment in Chemistry has been included in modules with over 250 students but had not been formally investigated at postgraduate levels. Anna found that active learning benefitted weaker students and was favoured by female respondents in a survey but students were concerned about their own and other students' competency to mark work.



Dr Anna Roffey

Finally, Paul Bartlett, Principal Teaching Fellow in the Department of Physics and Astronomy spoke about his research on extending Physics laboratory assessments where he addressed misconceptions and limitations of traditional Physics labs. Paul has introduced a verbal assessment grade which considered a student's attitude to laboratory Physics and their ability to query, explore and progress. This encouraged students to look beyond the lab script, collaborating with other groups and finding things they would otherwise have missed. Oral assessment rewarded beneficial behavior and successfully changed students' views of the purpose of Physics labs.



Dr Paul Bartlett

Before breaking for lunch we heard short abstracts for research to exploit potential collaborations from the event and enjoyed the inaugural meeting of the MAPS Journal Club. Victoria Hilborne, Senior Teaching Fellow in the Department of Chemistry, proposed development of training for PGAs to deliver inductive, inquiry based learning in Physical Chemistry lab classes. Gabriel Cavalli, Senior Lecturer at the School of Engineering and Materials Science at QMUL discussed his research into language issues in STEM education and proposed building a resource, SEE-U Science and Engineering English Usage. Jasvir Bhamrah, Teaching Fellow in the Department of Physics and Astronomy at UCL proposed examining the role of feedback in computing courses.

We were very fortunate to end the day with two excellent speakers. Dr Holly Hedgeland, Senior Lecturer in the School of Physical Sciences at the Open University shared her research into the effect of question type on the gender gap in Physics. Holly's focus had been FHEQ level 5 modules, assessed by interactive computer marked assignments, multiple choice questions and open response questions and found that scaffolding of questions helped mid-scoring students the most and could perhaps be used to reduce the effects of male bias which were evident in certain types of question. She also questioned gender gaps in force concept inventories. Holly's work stimulated much discussion.



Dr Holly Hedgeland

Our final speaker was Prof Simon Lancaster, Director of Learning and Teaching in the Department of Chemistry at the University of East Anglia. A strong advocate of active learning in lectures, Simon discussed the role of peer instruction and active learning in overcoming student misconceptions and how to demonstrate whether these pedagogies help students. Simon also highlighted the issue that student satisfaction is often higher with traditionally delivered lectures but mean attainment increases with lectures including active learning and how to solve the dilemma.



Prof Simon Lancaster

The day inspired much discussion during coffee and lunch with networking continuing for several hours in the Marlborough Arms during the evening which we hope will result in new collaborative initiatives into educational research and further such meetings. The event was organised by Jasvir Bhamrah and Elinor Bailey with funding from the UCL Research Staff Development Programme.

Jasvir Bhamrah
Senior Teaching Fellow

Outreach

Outreach Days

Ogden School physicist of the year

For our Ogden School Physicist of the Year we held our awards ceremony at the Institute of Physics London headquarters. Fourteen winners from Year 7 and Year 10 pupils collected their prizes and certificates, bringing their teachers, parents

and guardians to help celebrate their success over the year. Dr Andreas Korn gave a talk on his research and we were served a fully vegetarian and vegan buffet in an effort to reduce our carbon footprint and promote sustainability.



Dark matter day (2019)

The cold winter nights were joined by the return of Dark Matter Day held on the 30th November every year. With fantastic contributions by PhD students Nicolas Angelides and Robert James and a whole host of physics and astronomy and natural sciences undergraduate helpers. We spoke with A-level pupils and members of the general public about the mysteries of Dark Matter. With the aid of a prop or two we asked and answered as many questions as we could, but importantly giving an insight into just how much there is still to uncover.

Astrophysics summer school

Last summer twenty-four Year 12 pupils joined us for a 5 day Widening Participation funded residential summer school. With astrophysics as the main subject, using a hall of residence as a base we visited the main campus, UCLO and MSSL for tours and activities themed around Lunar exploration to coincide with the 50th anniversary of the Moon landings. Evening activities were planned alongside with the physics undergraduate student leaders acting as guides day and night. Giving these pupils some experience of what it would like to be a physics student at UCL.

NeutriKnow coding

Expanding on their work from last year, undergraduate students Danny Gold and Fern Pannell, founders of their educational coding company 'NeutriKnow', have continued to deliver coding classes to larger cohorts of Year 11–13 pupils. Through funding from UCL Widening Participation, five weekly classes were combined with a project and closing ceremony celebrating students' work. Presenting on projects of Quantum, Nuclear, Astro, Atomic, and Classical Physics to the rest of their cohort and student leaders.



As well as providing opportunities for pupils to learn code, this initiative has given undergraduate students vital teaching experience. The team of demonstrators; Arti Vasanthakumaran, Ewan Miles, Kai Jenkins, Leonardo Corsaro, Marion Thomas, Michael Schick, Ross Dobson and William Wookey, did a superb job in troubleshooting code, and working closely with pupils as they learnt how to problem solve and work in teams in a University setting. Danny and Fern are now looking to scale this up and are exploring the possibilities of making their course available across the UK.



HEP masterclass and more went virtual

Our High Energy Physics Masterclass went virtual this year with CERN unable to provide the usual excellent link up due to the lockdown, we nevertheless carried on and ran the activities during an online session instead. We had over 50 people joining us on the live broadcast where a group of intrepid physics undergrads troubleshoot technical issues remotely and guest lecturers and Q&A were provided by link ups with Prof Jonathon Butterworth and Dr Andreas Korn. Dr Zara Grout produced an excellent PowerPoint presentation for the virtual meet even though she had left

UCL by the point the masterclass was held. The pupils and teachers that joined us left great feedback, the content was challenging but rewarding and despite the unconventional method of teaching everything went extremely well. The experience pushed us to explore more virtual opportunities with Summer Schools and Asteroid Day being delivered using all the lessons we learnt from taking our outreach virtual.

Mark Fuller

Outreach Co-ordinator and Ogden Science Officer

Your Universe, the UCL festival of astronomy and particle physics

This was the 15th edition of the festival, now well established as the main outreach event of our department.

This year the festival had access to the large areas of both north and south UCL cloisters, which allowed a more comfortable layout of exhibits with diverse themes from the Atlas detector at the LHC, to the value of infrared astronomical imaging, telescope optics, aurorae, the lives of stars and for the first time, the robotic exploration of Mars and galaxy classification.

Following the usual format, on Friday we welcome pre-booked school groups and Saturday afternoon was open to the general public.

Once again, we were not lucky with the weather, so the planned telescope observations of the Sun, Moon and Venus were not possible.

The festival culminated with the traditional Saturday evening panel discussion, this time celebrating the 30th anniversary of the Hubble Space Telescope. The Eventbrite free ticket demand for this event was so overwhelming that the original plans to use the Gustave Tuck Lecture Theatre had to be changed in favour of the much larger Chemistry Auditorium. The UCL Room bookings and security teams were very helpful in this last-minute contingency.

The panel discussion was introduced and chaired by Dr Antonia Bevan. The panelists were Prof Chris Riley, Prof Richard Ellis, Dr Stephen Finney, Prof Jay Farihi and Affelia Wibisono. Their short presentations covered a wide range of topics, from the HST itself, to the conditions at the early universe, the mystery around its rate of expansion, exoplanets and Jupiter's aurorae.

The record breaking 200 plus audience mainly from the general public and families, participated in a lively discussion that went on for more than one hour.

For more details, summaries of the presentations can still be found on the festival website: www.ucl.ac.uk/your-universe

Along the years, the festival has grown in size and complexity, so there is now a managing team in place.

Mark Fuller, outreach coordinator for the department, is in charge of departmental funding, school groups, student demonstrator team, day-to-day logistics and Eventbrite promotion.

Karen Meekings, astronomy certificate alumna, volunteers her professional management and insight skills and oversees the general organisation and logistics. Karen is an invaluable addition to the team. Katie Grocott, also certificate alumna and UCL Communications Manager, has been collaborating as a graphic designer and promotion. Katie has also contributed presentations about extra solar planets.

Francisco Diego, Festival Founder and Director, is in charge of UCL venue/AV display bookings, alumni volunteers, lectures and panel discussions.

Looking ahead, the project is now ready to include more topics and in need of reaching more secondary student audiences and teachers.

There are important challenges calling for new strategies on demonstrators/explainers recruiting, including the corresponding funding.

This would be in addition to the fundamental contribution from certificate alumni volunteers, who always bring a rich variety to the presentations.

Hopefully this will help achieving a fresh and more coordinated approach to public/schools outreach in our department.

Francisco Diego,
Your Universe Festival Director



Karen Meekings explains the robotic exploration of Mars.



Part of the audience at the HST30 panel discussion that took place in the Chemistry Auditorium.



HST30 panel: Antonia Bevan chair, Prof Chris Riley, space historian, Prof Richard Ellis, cosmologist, Dr Stephen Finney, cosmologist, Affelia Wibisono, planet atmospheres and Prof Jay Farihi, exo planet expert.



Nicolas Angelides and Louie Corpe explain the basic physics behind the Large Hadron Collider.



Prof Giorgio Savini demonstrates the advantages of infrared imaging and its applications in astronomy.



Stewart Coulter, certificate alumnus, explains the operation of astronomical telescopes.



Irene Wears, certificate alumna, explains the history and applications of the Hubble Space Telescope.



Imaging experiment using simple optical benches and lenses.



Maria Niculescu-Duvaz and Tim Parsons and an interactive display about the classification of stars.



Ross Dobson explains the use of modern astronomical telescopes and the facilities as the UCL observatory.



Mark Fuller introduces the experiment to demonstrate the scales in the solar system.

The Centre for Doctoral Training (CDT) in Data Intensive Science

UCL's Centre for Doctoral Training in Data Intensive Science, based in Physics and Astronomy, has gone from strength to strength over the last year. A 3rd cohort of students started in September 2019, and a 4th will start in September 2020. At this point, the CDT will host 43 students, who work on subjects from across High Energy Physics and Astronomy.

Alongside their academic training, students undertake group projects and placements at some of the CDT's many industrial partners. A group of first year students have received excellent feedback from their project with NCC Group, a cyber-security company, whereas Constantina Nicolau, a second year student, was also awarded Best Workshop Paper at the IEEE Advances in Natural Language Processing Conference in Spain. Her winning paper was based on research emerging from a group project with ASOS, one of the CDT's industrial partners.

The CDT has continued its successful seminar series, bringing speakers from across academia and industry to share ongoing work related to Data Intensive Science. These seminars, which are open to both CDT members and the broader UCL community, have attracted large audiences, and helped foster interdisciplinary collaboration. Members of the departments of Computer Science and Mathematics, among others, have presented work as part of the series, alongside many external speakers from organisations including Babylon Health, Deepmind, and the Flatiron Institute.

The CDT has also run events which have brought together industry partners, academics, and students to discuss potential collaborations. The CDT was particularly pleased to welcome UCL's Provost to its most recent such event in December 2019.

The Centre has also commenced work on a ground-breaking collaborative project with academic partners in Jordan, funded by a £300k grant from the Newton Fund. This project is helping create the next generation of data scientists in Jordan, using the CDT's established training expertise.

A course in machine learning has already been successfully delivered electronically to Jordanian students, and the Centre hopes to arrange a collaborative summer school during the 2020-21 academic year. A launch event in April 2020 saw a range of staff from across UCL speak about the programme, and the CDT looks forward to expanding its activities in Jordan over the next year.

As the first cohort of students enter their final year of study in September 2020, the CDT is excited about what the future holds.

Nikos Konstantinidis and Ofer Lahav
Co-Directors

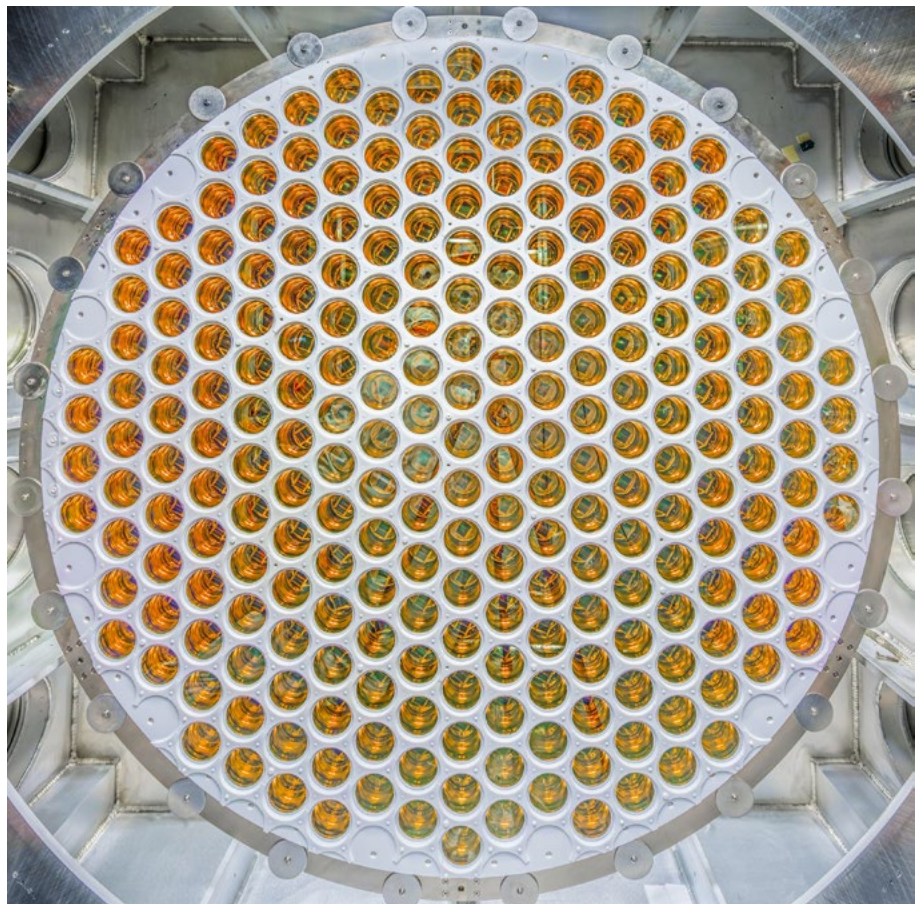

The PMTs used by 3rd year CDT student Omar on placement in South Dakota, USA.

Career Profile

Graduate Destinations

Total Number of Graduates: 194
Response Rate: 55%
Median Salary: £33,250
(full time employment)

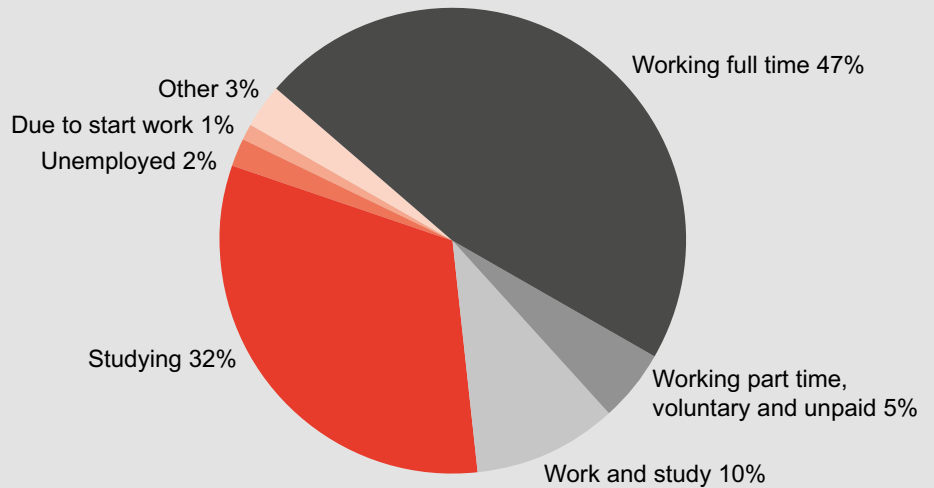

The data is for the 2017/18 graduating cohort, for all students

Sofia Qvarfort



I completed my PhD in 2020 as part of the Delivering Quantum Technologies Centre for Doctoral Training at UCL, supervised by Alessio Serafini. Seeking to continue my research, I applied for and was awarded two EPSRC Doctoral Prize Fellowships at both UCL and Imperial College London. In a unique arrangement, I am now undertaking both fellowships part-time at the two institutions, in Prof Peter Barker's and Prof Tania Monteiro's group at UCL, and in Dr Michael Vanner's group at Imperial.

My research focuses on the theory of quantum optomechanical systems. These systems consist of light ('opto') that interacts with a small mechanical element. When cooled down to near absolute zero, the mechanical elements can take on quantum-mechanical properties and behave very differently from what we are used to from the world around us. Quantum properties are especially beneficial for sensing, and as a result, optomechanical systems are being studied in laboratories at UCL and elsewhere to probe novel regimes of physics and to detect extremely weak effects, like gravitational waves. I am also interested in the study of entanglement – a property of quantum systems that increases the correlation between two systems beyond what would have been otherwise possible. Together with Prof Alessio Serafini and Prof Sougato Bose, I recently concluded work on the entanglement of the Hydrogen atom, which despite being one of the most common entities in the universe, had not yet been rigorously studied in this regard.

I was born with a visual impairment (short-sightedness that is not correctable by glasses). To inspire other visually impaired people to study at university, I run a website (www.vipatuni.com) and a podcast called **University InSight** that aims to share the experiences of visually impaired former students. I have also been involved in initiatives to encourage girls to study physics by organising an open day at UCL in collaboration with the TechGirls charity. I hope to continue these activities alongside my research in the future.

I've worked on a variety of projects across different sectors, tackling problems in natural language processing and computer vision.

My time at UCL allowed me to experience being a research scientist and gave me foundation for an exciting new career.

David Gao – Bridging the gap between science and industry



When I first started my scientific career after graduating with a Chemistry degree, I found myself in an industrial lab working for a big company. At Chevron, in their analytical chemistry and components development labs, I was able to apply my skills towards improving fuel economy and reducing our reliance on hazardous materials. However, I soon noticed a disconnect between fundamental research and industrial goals. The most iconic aspect of research is exploring the unknown. Academic researchers are happy to embrace this uncertainty and welcome discoveries unrelated to the original topic of study but rarely get to directly see their work applied in the “real world”. In contrast, commercial researchers get to see their work turn into tangible products but must carefully focus their efforts towards business needs. But why not have both?

To obtain the best of both worlds, I returned to academia and joined Prof. Alexander Shluger’s group at University College London for a Ph.D. where I spent the next years of my life focused on the theoretical modelling of materials properties. After completing a postdoc at the London Centre for Nanotechnology, I founded Nanolayers Research Computing LTD with a few like-minded colleagues. Through our new company we were able to select projects that interested us scientifically and take them all the way through to the development of marketable products. The skills I gained throughout my Ph.D. helped me not only solve scientific problems, but also mentor new hires and manage large international projects and collaborations. Last year I completed my M.B.A. and joined the Norwegian University of Science and Technology as an Associate Professor in the Materials Theory group. As I explore opportunities in both academia and industry my path continues to take me along the edge between the two worlds.

Amal Vaidya



I started my PhD at an exciting time for particle physics. The second run of the Large Hadron Collider (LHC) had just started at a new, higher collision energy and a variety of searches for signs of new physics were underway.

I hadn’t made my mind up on what I was going to do after graduating but after focusing on condensed matter physics during my masters it was this environment that motivated me to stay in physics and apply to work on the LHC.

I had the opportunity to move to CERN, living and working within a collaboration of amazing physicists from around the world. My graduate work involved a variety of interesting things: trying to improve the performance of particle physics detectors, test new algorithms for detecting specific particles and performing precise measurements of the standard model, our current best theory for fundamental physics.

With protons being collided once every 25 nanoseconds at the LHC I was exposed to machine learning and big data early on in my research. Due to UCL’s partnership with industry I had the chance to work on a machine learning project with ASOS in the final few months of my PhD. I found that while the work I was doing as a physicist was interesting, applying the skills I’d learnt to solve problems with real world applications was something I was more interested in. At the same time, there is a growing focus within physics on dedicated machine learning research.

I ultimately decided to leave academia and I currently work as a data scientist at a start up called Faculty.

I’ve worked on a variety of projects across different sectors, tackling problems in natural language processing and computer vision.

My time at UCL allowed me to experience being a research scientist and gave me foundation for an exciting new career.

Professor Serena Viti



I moved to the UK in the early 90s to study Astrophysics at Queen Mary University of London. In 1994 I moved to UCL to start my PhD in molecular astrophysics under the supervision of Prof Jonathan Tennyson. My PhD was an interesting ‘mixture’ of molecular spectroscopy and astronomy, as I studied the opacity of molecules in the atmospheres of very cool stars, a field that, in the era of exoplanets, has now blossomed. Although I remained interested in this topic, I switched research focus with my first postdoc and moved to work in the field of Astrochemistry and Star Formation.

From 1997 to 2002, I worked in the Astrophysics group at UCL, first as a postdoctoral researcher in the group of Prof David Williams (the Perren Chair of Astronomy and Head of the Astrophysics Group at the time), and then as a fixed term lecturer. During this time, I became interested in how best we can use the observations of molecules as tools to understand the physics of the gas that forms stars. These were the years where I developed the two astrochemical codes that then became central to my career as an Astrochemist.

The early 2000s were very exciting for Astrochemistry because the community was getting ready for the Herschel Space Observatory (eventually launched in 2009). This infrared space observatory would come to revolutionise our view of how stars form. Hence, I was very fortunate in 2002 to get a position as an Herschel researcher at the Centre for National Research in Rome, where I was employed to design some of the scientific programs for Herschel. I only stayed there a year though, because while there, I applied for a PPARC (now STFC) Advanced Fellowship (the ERF of today) and was awarded one, which I chose to take back to UCL in 2003, where I remained ever since.

During my many years at UCL, my group and I contributed in laying strong foundations in the methodologies for exploiting and interpreting the submillimetre emission of molecules from the interstellar medium. Our work led us to study how the most common interstellar molecules form, under what conditions they become abundant and hence which physical parameters they trace. I was lucky enough to have great PhD students and postdocs who helped me successfully initiate observational campaigns on dense gas molecular tracers in active galaxies, and adapt tools from galactic astrochemistry to pioneer their use in the new field of extragalactic astrochemistry. In the most recent years, inspired also by the UCL Centre for Doctoral Training in Intensive Science, we developed new and original approaches for the interpretation of astrochemical modelling using Bayesian and Machine Learning techniques, never before used in astrochemistry. In 2019 I was awarded a €2.4M ERC Advanced Grant to support these innovative studies in extragalactic astrochemistry.

Finally, central to my life at UCL were also the many roles I enjoyed taking on in the Department. In particular, in September 2016 I became the Head of the Astrophysics Group, a role which I now pass on to my colleague Prof Giovanna Tinetti, as I am just about to embark in my next new adventure at Leiden Observatory. My life at UCL is not over yet, however, as I shall remain associated to the Department of Physics and Astronomy for quite some time still!

Alumni Matters

We hope that as a member of our extended family that you and yours are well and safe in these uncertain times.

The 7th Physics & Astronomy Gala Dinner took place on 1 November 2019 in the nearby Ambassador Hotel. There were over 110 people in attendance, including alumni, undergraduate and postgraduate prize-winners with their guests, members of staff, the Dean of the MAPS Faculty, Professor Ivan Parkin, and members of the student Physics Society. In the award ceremony, the Head of Department, Professor Raman Prinja, expounded on our students' numerous achievements and successes.

The inaugural Technician of the Year award was given to Derek Attree, whose multiple contributions to the Department are "hard to overestimate".



Dorothy Duffy

The after-dinner speech was given by Professor Dorothy Duffy, a member of the Condensed Matter and Materials Physics group as well as the LCN. With a PhD from Imperial College, Professor Duffy also has worked at Reading University. Now retired, she applies modelling techniques to a diverse range of systems and processes,

from organic-inorganic interfaces to radiation damage. She also played an important teaching role in the department, including project supervision, strand leadership, and her chairing of the MSc exam board.

Beforehand, in the Massey Lecture Theatre, the Annual Physics & Astronomy Lecture, entitled "What has the Higgs discovery done for you?", was given by Dr Tim Scanlon, with a brief reception afterward.

Current events make the planning for the next Gala Dinner uncertain. We will not hesitate to send details out as soon as they are made available. See you there!

Nevertheless, if you have any suggestions for initiatives that may bring us together, online or off, please let us know. And let us know if you would like to help out with anything.

Stan Zochowski, Alumni Relations head
(stan.z@ucl.ac.uk)





Observatory News

Student research at the UCL Observatory

For over 90 years the UCL Observatory has provided both training and research resources for undergraduate students in the Physics and Astronomy Department. Continuously updating and modernizing its facilities through the decades, the Observatory provides a range of on-site and remote access to both classical and modern telescopes as well as its own dedicated computing facilities which allow operation of on-site telescopes as well as submission to a partner robotic telescope network in both hemispheres.

At the UCL Observatory we reconcile the training in experimental techniques with hands-off remote operation and complement both with all the data science skills which current astronomers and astrophysicists make use of.

Below are two examples of topics from this year's 3rd year group projects.

Eclipse timing variations in post common envelope binaries

This year, one of our 3rd year group projects investigated timing variations of the post-common envelope binary DE CVn by obtaining eclipse light curves (Fig.2). Combined with historical data, the timings showed a faster quadratic decay of the orbital period than previously observed (possible evidence of a circumbinary disc in the mass range 10^{-4} to $10^{-2} M_{\odot}$) and a cyclic perturbation (Fig.1) consistent with a previously hypothesized exoplanet and a possible revision of its parameters.

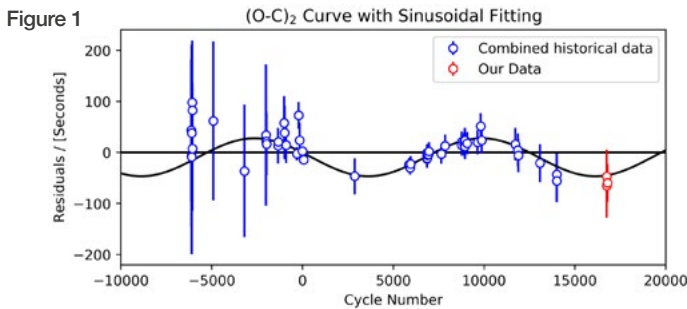

The origins of Lenticular galaxies

Students used both catalogue data and observations with the UCLO robotic telescopes and the Telescope Live network to compare bulge-to-total light ratios between lenticular and spiral galaxies (Fig-lower right). This allowed them to infer that lenticulars appear to represent a distinct physical class rather than one that evolved from spiral galaxies which lost their gas.

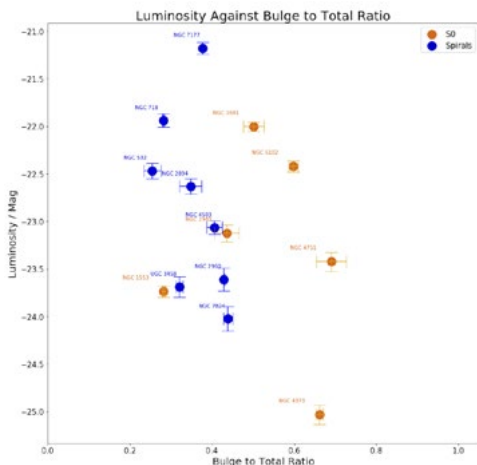

Project students: Dorad Hasani, Florence Penfold, Andreea-Alexandra Varasteanu, Iga Zacharewicz
Project supervisor: Prof. Richard Ellis

Research in solar system objects, exoplanets, variable stars and galaxies

Throughout the year, a range of research topics are integrated in all our courses. These include, planet observations, asteroid monitoring, exoplanet transit ephemeris (observations and refinement of), variable star measurements as well as photometric observations of other galaxies and galaxy clusters.

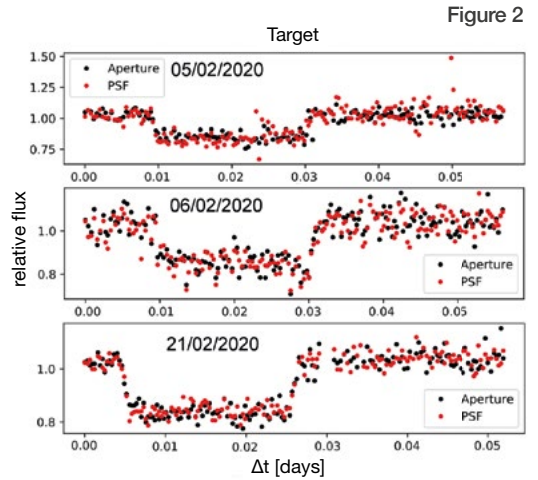

Project students: Ryan Brady, Nicholas Clark, James Marsden
Project supervisor: Dr. Jay Farihi

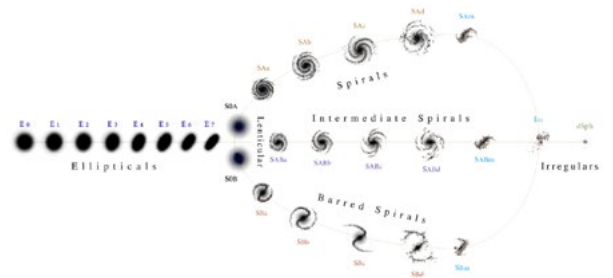

Hubble – de Vaucouleurs diagram for galaxy morphology adapted from 'Hubble, EP, 1926. Extra-galactic nebulae.' The Astrophysical Journal, 64, pp. 321-369. Image credit: Antonio Ciccolella/M. De Leo

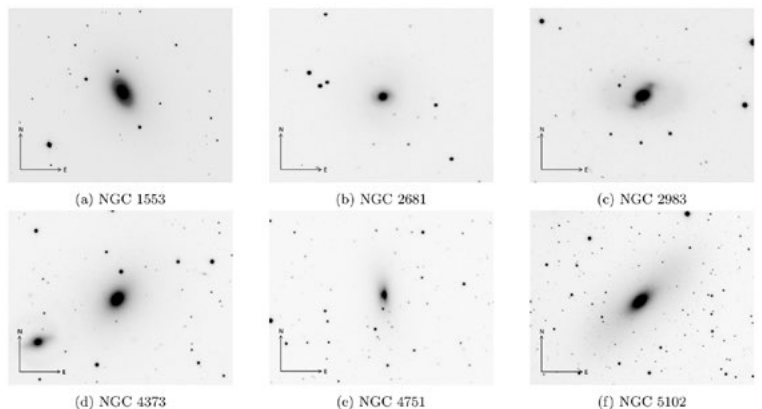



1998OR2 – A close reminder

The addition of our new (80cm) Perren telescope, together with the Telescope Live network allow us (among many other things) to take part in Near Earth Object (NEO) search and monitoring campaigns by tracking asteroids which fly close to Earth and represent a potential collision threat in the future.

This year we observed a number of asteroids including NEOs: 162082, 163373 and more recently 1998OR2. The latter is a 2km asteroid (one of the largest NEOs) which approached Earth at less than 16 Lunar Distances and allowed us to take clear astrometry to refine orbital parameters and photometry to calculate light curves.

Every year, thousands more objects are being discovered and require monitoring in order to allow careful prediction of future close approaches.

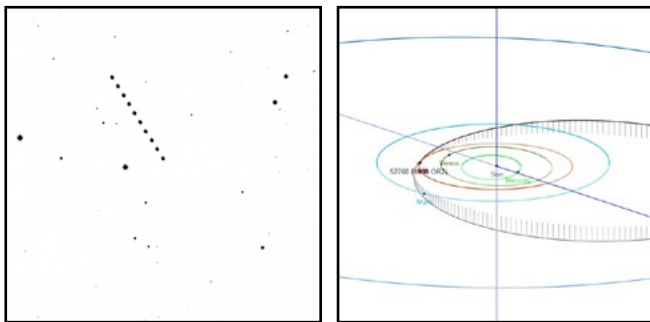

1998OR2 – 10s frames @ 1 minute intervals during its close approach (29th of April)

Partnership with Telescope Live[©]

Our partnership with the Telescope Live network of robotic telescopes has become an essential part of our observational program. With telescopes in Chile, Spain and Australia, it not only allows us access to good observing sites and constantly operating telescopes, but it enables observations in both hemispheres as well as hand-over of targets through a range of time-zones.



LHA 120-N11 in the Large Magellanic Cloud. Image processing: Prof. I.Howarth

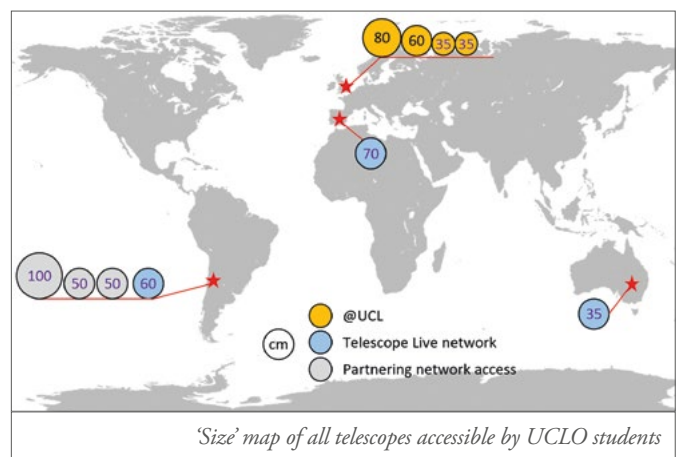
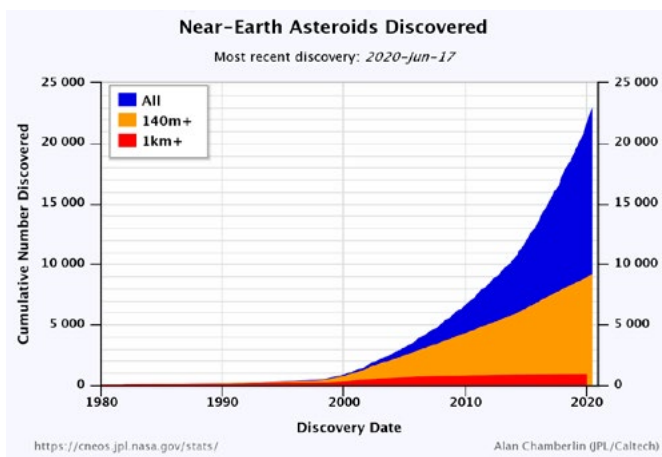

'Size' map of all telescopes accessible by UCLO students

COVID19 and the Observatory

All modules taught at the Observatory make use of a computer cluster managed locally that allows remote connection by the students. As lockdown occurred in March 2020, we transitioned immediately to a remote

teaching and learning mode, with students accessing all necessary teaching material and assessment procedures, as well as submitting observations to all our telescopes thanks to our web platform.

Observatory News cont.

The new, state-of-the-art Perren telescope was unveiled on 6th November 2019 at the UCL Observatory (UCLO) by Astronomer Royal, Lord Martin Rees, to celebrate 90 years since the observatory was first opened by then Astronomer Royal, Sir Frank Watson Dyson.

The event also marks 100 years to the day since Professor Arthur Eddington and Sir Frank reported the first experimental evidence for general relativity using the 1919 Solar Eclipse – the discovery that made Albert Einstein a household name. The newly installed 80cm reflector is the facility's biggest telescope and joins a suite of five permanently mounted telescopes housed in the observatory's iconic domes.



Professor Michael Arthur, UCL President & Provost, who attended the unveiling, said: “The ground-breaking discoveries made at the UCL Observatory, such as the first sighting of a supernova by our first year students epitomise the benefits of research-based education that we are proud to offer all undergraduates across UCL. With the new Perren telescope, we are providing our students with the best-equipped teaching observatory in the UK and I look forward to seeing what mysteries of the universe they uncover next.”

Professor Giorgio Savini, Director of the UCLO, said: “The unveiling marks the completion of a 14-year fundraising process and substantial renovation of our astronomical teaching observatory, which is scientifically transformative for UCL Physics & Astronomy.”

Professor Raman Prinja, Head of UCL Physics & Astronomy, said: “UCL is at the forefront of many discoveries concerning exoplanet science, cosmology and stellar astrophysics, and contributes to ambitious international collaborations to probe the most elusive and mysterious phenomena in the cosmos, from black holes to dark matter. It is only fitting that our astronomical observatory provides the best technology and environment to educate and train the next generation of astrophysicists to push the boundaries of knowledge even further.”

Lord Martin Rees, Astronomer Royal, said: “Astronomy is a fundamental science and it is also the grandest environmental science. I am sometimes asked ‘what perspective does astronomy give to us regarding everyday life?’ I think there is one thing it does, which is to give us an awareness of the far future. This century is special. This is the first century in the 45 million from which Earth existed in which one species, ours, has the future in its hands. We are living on this pale blue dot in the cosmos, which is a special place, and we are here at a special time. That is a salutary thought for all of us, whether we are astronomers or not.”



Michael Arthur and Martin Rees

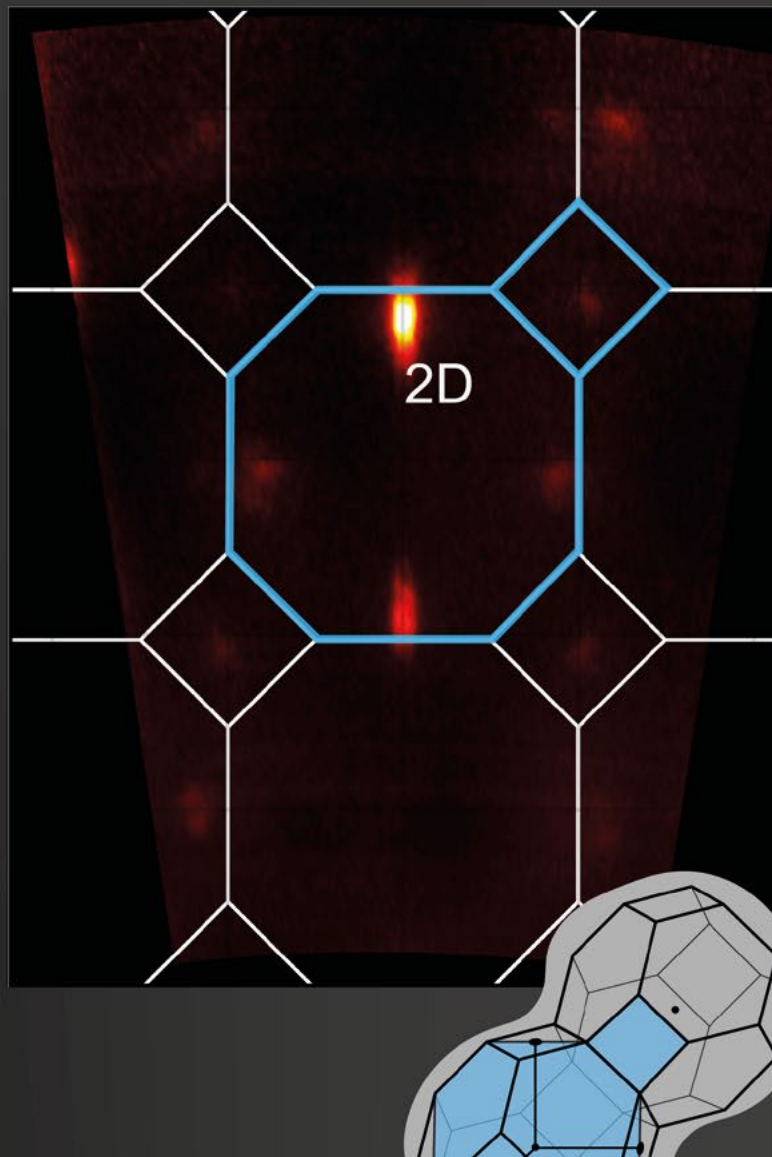
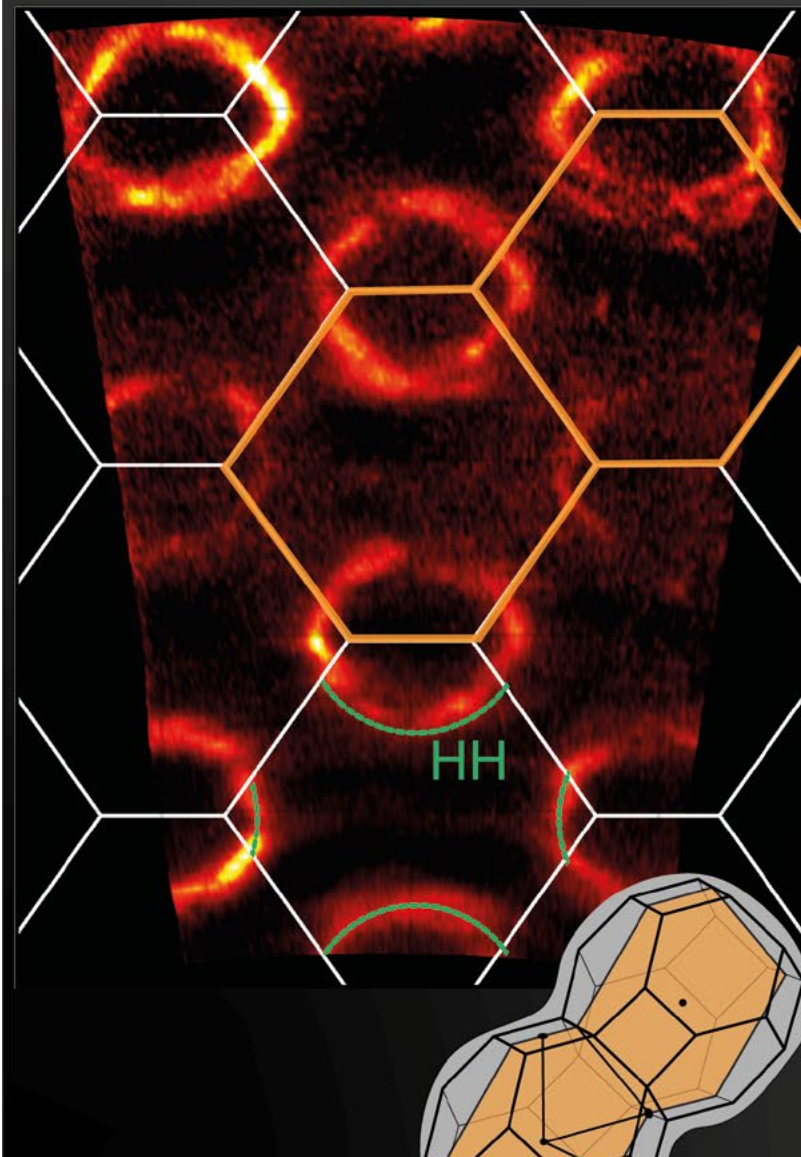
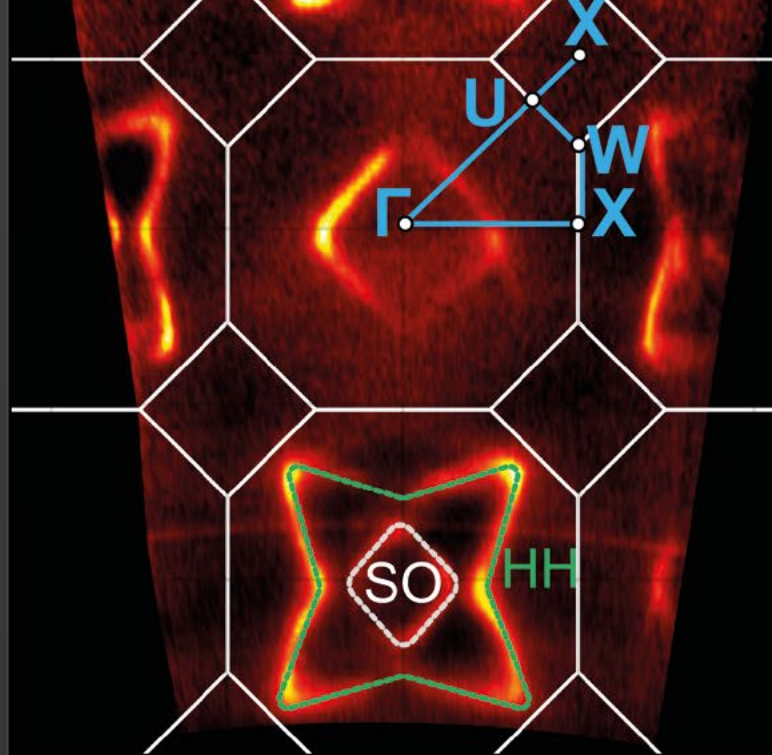
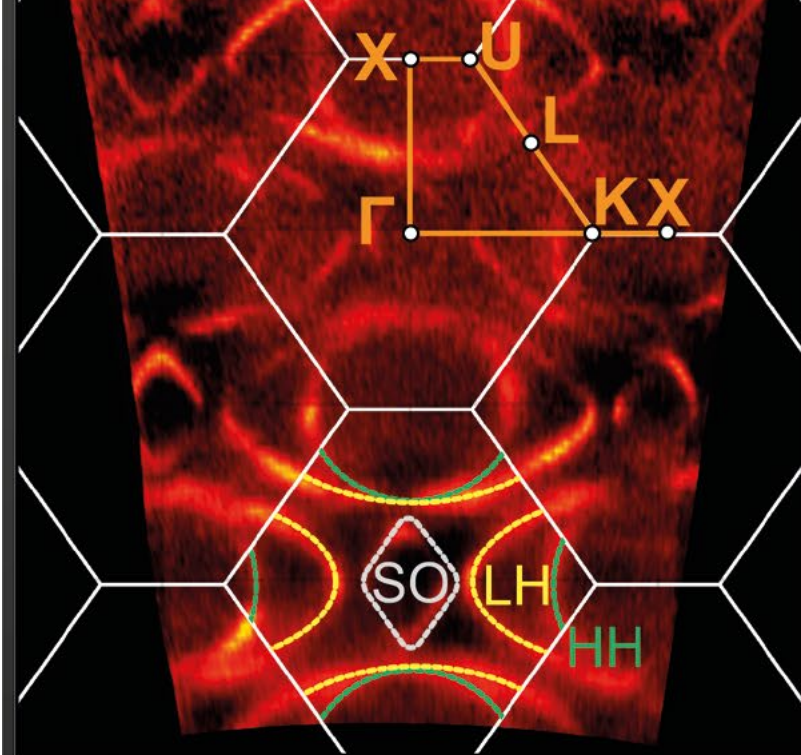

Academic Showcase

Staff News

Promotions

We are very pleased to announce the latest round of senior promotions; congratulations to the staff listed below on their well-deserved achievements:

Promotion to Professor

Professor Jay Farihi (Astro)

Professor of Astrophysics

Professor Christopher Howard (CMMP)

Professor of Materials Physics

Professor Amelie Saintonge (Astro)

Professor of Astrophysics

Promotion to Professorial Teaching Fellow

Professor Paul Bartlett

Professorial Teaching Fellow

Promotion to Associate Professor

Dr Isabel Llorente Garcia (AMOPP)

Associate Professor

Dr Ingo Waldmann (Astro)

Associate Professor

Promotion to Principal Teaching Fellow

Dr Daven Armoogum

Principal Teaching Fellow

Dr Elinor Bailey

Principal Teaching Fellow

Dr Nick Nicolaou

Principal Teaching Fellow

Retirement

Dorothy Duffy

Professor Dorothy Duffy has retired after a distinguished scientific career.

Dorothy's interest in materials physics was sparked by a brief spell with British Aerospace that came in between her BSc (Physics, Durham 1976) and her Ph.D. (Imperial 1981).



In a collaboration between Reading University and the UK Atomic Energy Authority, Harwell, she helped develop the first computer programs for materials simulation. These were used to calculate the properties of defects in crystals, which could then be used for predicting radiation damage in nuclear power stations.

In 1996, following a career break, Dorothy was awarded a Daphne Jackson Fellowship. Since then she has applied computer modelling methods to a diverse range of systems and processes, from ferroelectric materials and biominerals, to radiation effects in materials for fission and fusion. She was appointed to a lectureship at UCL in April 2005 and promoted to Professor in 2015.

To mark the occasion of Dorothy's retirement, the Department (CMMP Group) held a meeting and Dinner in Dorothy's honour that was attended by many colleagues, past and present, from UCL and beyond. All agree that as well as being a most excellent scientist, Dorothy has always been the best of colleagues, and we wish her a long and happy retirement.

Retirement

Professor Ian Howarth

Professor Ian Howarth retired at the end of 2019 following a distinguished research and teaching career at UCL. The popularity and effectiveness of Ian's teaching was reflected in the award of the Department's annual teaching prize, and he was Director of the UCL Observatory at Mill Hill during a period of rapid technical development there, including introducing robotic observing.

Ian carried out his PhD project at UCL under the supervision of Sir Robert Wilson, analysing the UV spectra of massive stars that had been obtained by the recently launched NASA-ESA-UK International Ultraviolet Explorer (IUE). This and subsequent work helped establish him as an internationally leading figure in massive star research. Following the award of his PhD in 1982, Ian was appointed to a Lectureship in 1984. Amongst the research topics that he has made key contributions to are the time variability, mass loss rates and terminal velocities of the stellar winds of OB stars, the properties of massive binaries, the magnetic fields and polarisation properties of single stars and interacting binaries and the study of stars rotating close to break-up velocity. Ian also contributed a number of important Open Source software packages to the community, including the widely used Dipso package for the analysis of stellar and nebular spectra.

Ian was already an accomplished astronomer even before starting his PhD research, having published over a dozen refereed papers in the *Journal of the British Astronomical Association* and becoming Director of the BAA's Variable Star Section while still an undergraduate. As a Fellow and a very active member, he later served as Councillor, Senior Secretary and then Vice-President of the Royal Astronomical Society. Travel and ornithology feature prominently in Ian's leisure activities, with the two often combined, as in the trip to Ethiopia that he undertook immediately following his retirement event, perfectly timed as it turned out to beat the Covid-19 lockdown. We wish Ian an eventful and a fulfilling retirement.



'En route to Abuna Yemata Guh, Ethiopia'

Celebrating Ofer Lahav's 60th Birthday



Ofer Lahav reached 60 years of age in April 2019. To celebrate his distinguished and remarkably broad career, we held a conference in his honour.

The Conference, 'From Deep Learning to the Dark Universe' took place from 8–10 April 2019 at Cumberland Lodge, a 17th-century Grade II listed country house set in the heart of Windsor Great Park, located 3.5 miles south of Windsor Castle.



Headline Research

A study of the effect of anisotropic gold nanoparticles on plasmonic coupling with a photosensitizer for antimicrobial film

Emergence of drug resistant bacteria has been one of the main concern for the public health in the recent times, especially for the treatment of the infection acquired in hospitals.

The plastic film described in this article utilizes super small gold particles shaped as rods (nanorods) or as sea urchin (nanostars) at the same time to a dye, crystal violet to kill the bacteria on its surface when exposing it to the light of a commercial lamp.

Films modified with gold nanostars killed 5 orders of magnitudes (5-log) of *E. coli* (gram (-)) in 4 h while introducing nanorods generated slightly smaller activity (4-log). Against gram (+) bacteria (*S. aureus*), the film is able to kill in 2.5 orders of magnitudes modified with gold nanostars and 3 orders of with gold nanorods.

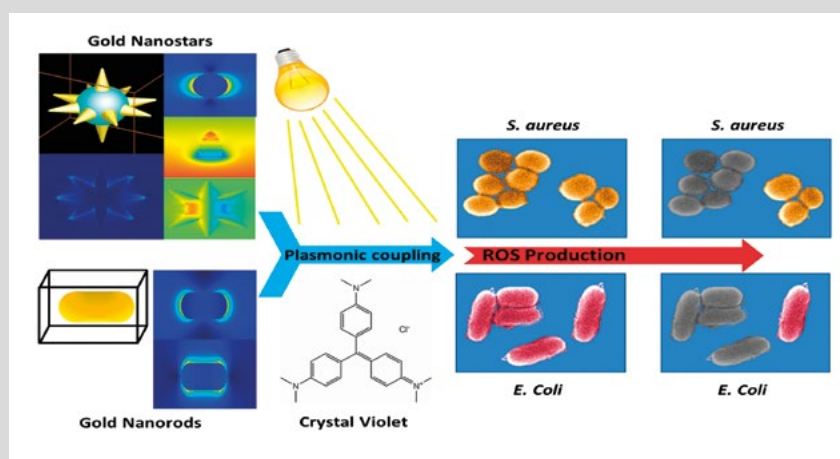

Full articles were published in ACS Applied Bio Materials:

<https://pubs.acs.org/doi/full/10.1021/acsabm.9b00838>

<https://pubs.acs.org/doi/abs/10.1021/acsabm.9b00343>

Francesco Rossi, Eng Huat Khoo, Xiaodi Su and Nguyễn T. K. Thanh

Research Degrees

January 2019 – December 2019

Henry I. B. Banks

Exotic forms of matter created by interactions with free-electron lasers
(Prof A. Emmanouilidou)

Nadir S. Basma

Structure and ordering in solvents and solutions of carbon nanotubes
(Prof C. Howard)

Stefanos-Horst Chalkidis

Optimisation and application of x-ray near-field ptychography with Fresnel zone plates
(Prof A. Shluger)

Mario Damiano

From space to ground: planetary atmospheres revealed through a machine learning approach
(Prof G. Tinetti)

Arthur E. Da Mota Loureiro

The Universe in harmonic space: neutrinos and dark energy
(Dr F. Abdalla)

Daniel M. Darby-Lewis

Beryllium mono-hydride: electron collision and spectroscopic modelling for fusion plasmas
(Prof J. Tennyson)

Soliman Edris

The ratchet effect with cold atoms
(Prof F. Renzoni)

Julian C. E Gaberle

Modelling of adsorption of atomic and molecular species on defective surfaces
(Prof A. Shluger)

Alexandros Giatzoglou

Towards laser cooling and trapping of unstable Caesium atoms
(Prof F. Renzoni)

Callum J. Gray

Field correlations in Coulomb gases
(Prof S. Bramwell)

John C. M. Gray

Many-body entanglement in classical & quantum simulators
(Prof S. Bose)

Marios Hadjimichael

Ferroelectric domains in lead titanate heterostructures
(Dr P. Zubko)

David J. Ingram

The solvation and regeneration of Ammonia Borane: a hydrogen storage material
(Prof N. Skipper)

Robert Jirschik

Hybrid quantum systems: resonator state preparation with Rydberg atom beams
(Prof S. Bose)

Richard T. Juggins

Superfluidity in coherently driven microcavity-polaritons
(Prof M. Szymanska)

Muhammad S. Kamaludin

Growth, modification and characterisation of organic semiconductor crystals
(Prof N. Curzon)

Andrew S. Maxwell

Strong-field interference of quantum trajectories with coulomb distortion and electron correlation
(Prof C. Figueira De Morisson Faria)

Michael A. McLeod

Cosmology and the local group in Λ CDM and modified gravity
(Dr F. Abdalla)

Davide Pincini

On the hierarchy of electronic and magnetic energy scales in novel 3d, 4d and 5d transition metal oxides probed by x-ray techniques
(Prof D. McMorrow)

Stefan Siwiak-Jaszek

Quantum synchronisation of molecular motions in bio-inspired energy transfer
(Prof A. Olaya-Castro)

Arianna M. Sorba

Configuration and dynamics of Saturn's disc-like magnetosphere
(Prof N. Achilleos)

Nicholas J. Tidy

The investigation of the properties of soft matter using optical traps; an investigation into microemulsions using optical tweezers
(Prof P. Jones)

Portrait of...

Professor Alexandra Olaya-Castro



Alexandra was born and grew up in Bogotá, the capital of Colombia. She loves the view of Monserrate, a 3,000 meters high mountain dominating the scene of the city centre of Bogotá. and has climbed that mountain many times in her life. She has also climbed other mountains.

She did her undergraduate in Physics Education at Universidad Distrital Francisco José de Caldas, and then a Master's in Physics at Universidad de Los Andes. During her Masters she investigated signatures of coherence in the light emitted by Bose-Einstein condensates of excitons in quantum wells. The research integrated ideas from quantum optics and many-body physics to propose a way of probing macroscopic quantum states of electron-hole pairs. It was at this time that her long-lasting love for quantum science and quantum optics began, when she became fascinated with the concept of quantum coherence, and when she understood she would like to do research for as long as possible.

In the autumn of 2002, Alexandra moved to the UK to do a DPhil in Physics at the University of Oxford thanks to several scholarships. Her doctoral research was on quantum correlations and quantum information processes that could be catalysed by asymmetric interactions of many-qubits with an optical cavity. At the end of her D Phil, she started investigating quantum effects in photosynthetic proteins. She found the physics of these organic proteins absolutely

fascinating, in particular the hypothesis that they would exploit quantum phenomena even in conditions where such phenomena are expected to be very short-lived. She was determined to pursue her own ideas to approach this research problem, so she focused on applying for junior fellowships. She was fortunate to obtain a three-year Junior Research Fellowship at the University of Oxford supported by Trinity College. During this time, she completed one of the works that she feels more content with during her career as it bridged approaches from physical chemistry and quantum optics in an unprecedented way.

After this fellowship, she was ready to start a research group. Her thinking at that time was a bit radical: She either obtained a long-term fellowship that would allow her to start a research group or she would be out of academia. She also had one clarity: though she enjoyed doing research, her priority was the place she would live. She was missing a buzzy and diverse city.

In 2008 Alexandra joined the Department of Physics and Astronomy at UCL thanks to an EPSRC Career Acceleration Fellowship. One of the reasons that weighed strongly in her decision to apply for the fellowship with UCL as a host was the fact that, at the time, the Physics department had the highest percentage of women academics in comparison to other universities in London.

Alexandra has had an exciting academic career at UCL even if it took her some time to find her voice. She obtained a Lecturer position in September 2011, she achieved her promotion to Reader in 2015 and became Professor of Physics in 2018. In between she built a family with a marvellous human and they have two gorgeous kids.

Her current research aims to bridge quantum science and biology at the molecular level by understanding non-trivial quantum processes that influence the performance of prototype biomolecular systems and by contributing to the development of the theoretical methods of quantum science to investigate complex molecular systems. Part of what she enjoys the most of about her work is the collaboration with the students and postdocs that she has had the pleasure to supervise.

One of the ongoing projects that she is most excited about is a theory-experiment collaboration she has with a colleague in Southampton to develop a quantum optics platform that, if successful, will allow them to provide new unambiguous evidence of quantum coherence at the single molecule level.

The experiments will attempt to test some of the theoretical predictions done in my group. It is like a dream come true. She is also very excited with the recent expansion of the theory they are developing towards an in-depth scrutiny of their understanding of the quantum-to-classical transition.

For Alexandra, the scientific endeavour is also about helping to transform the academy into a more inclusive and open-minded scenario. Science is to a large extent stagnated because is attached to old ways of thinking and stereotypes that do not let us appreciate the contributions made by all the members of our academic communities. She thinks, we need bolder actions to understand and confront our systemic and individual biases, especially against gender and ethnicity.

Several writers and scientists have inspired Alexandra throughout her life. Of recent, she has become an admirer of Olga Tokarczuk. She found her Nobel Prize lecture very inspiring. When talking about the proliferation of information and misinformation we are constantly exposed to, she expressed a thought I keep reflecting on: "It has turned out that we are not capable of bearing this enormity of information, which instead of uniting, generalizing and freeing, has differentiated, divided, enclosed in individual little bubbles, creating a multitude of stories that are incompatible with one another or even openly hostile toward each other, mutually antagonizing." For Alexandra, science should help us be truly free while united.

Dan Browne writes: I've known Alexandra since we were both Junior Research Fellows in Oxford, and I was delighted when she chose to join UCL. Alexandra has always taken an interdisciplinary approach in her work and has focussed on breaking down the barriers between different scientific traditions. She has shown how fruitful research can be when it reaches out beyond disciplinary boxes, when old questions can be reevaluated with new methods and with a new perspective. She approaches her teaching with the same attitude and is popular with students for the clarity and enthusiasm with which she engages them. Now as Vice-Dean for Equality, Diversity & Inclusion in the Faculty, she devotes the same energies to overcoming barriers of a different kind, helping departments to overcome obstacles to inclusivity and equality. This includes initiating the Faculty-wide conversations to challenge and change long-established practices and behaviours. These conversations can be uncomfortable, but by taking the lead in a positive and encouraging way Alexandra is helping the Faculty to move forward to be a place where every member is appreciated and can thrive.

Extragalactic Astrochemistry: the ALMA revolution

Molecules pervade the cooler and denser parts of our Universe, in particular the reservoirs of the gas that forms stars and planets as well as the gas in the centres of galaxies. For decades now, we have used molecules to explore and characterize these regions in our own Galaxy: the more complex the chemistry, the more details of the gas the molecules reveal.

Until very recently, due to their distance, even for galaxies close to us we were unable to zoom in and observe individual clouds of dense gas. ALMA, the Atacama Large Millimeter/submillimeter Array, has changed all this: its exquisite sensitivity and spatial resolution is showing us that chemistry in external galaxies is as complex as in our own Milky Way. Molecules, it seems, are universal and widespread.

How can we best exploit molecules to determine the physical conditions of these galaxies and their likely evolutionary status? The answer must lie on establishing a set of unique molecular tracers capable of characterizing different phases of the neutral gas in nearby galaxies, and to develop a methodology capable to extend it to the farthest galaxies.

The desire to use chemistry as a powerful diagnostic of galaxy evolution and formation motivated the ALMA Cycle 5 Large Program - ALCHEMI - a spectral scan of the central molecular zone of one of the most famous starburst galaxies: NGC 253. ALCHEMI will result in the most complete extragalactic molecular inventory and, together with many other high spatial resolution studies, will provide us with key molecular transitions that can unambiguously trace individual physical and energetic processes in active galaxies, as well as pave the way to a robust framework to guide astrochemists in the interpretation of molecules in nearby and distant galaxies.

UCL astronomers, Serena Viti and Thomas Greve, and their team, have an active role in the managing and exploitation of ALCHEMI.



Credit: ESO/C. Malin

In Memoriam

Cyril Henderson

Cyril Henderson was born in Durham in 1923. After wartime research on radar, sonar and radio, he studied physics at Bangor – UCL’s temporary wartime home – graduating in 1946. He stayed at UCL for a PhD in solid state physics, and was appointed Assistant Lecturer, rising to Lecturer and Reader. After his PhD he moved over to what would nowadays be called particle physics, working with Franz Heymann and Dick Jennings on the construction of a 4.5 MeV microtron and a beta ray spectrometer.

The UCL Bubble Chamber group was formed in 1955, and initially consisted of Cyril together with his namesake Cyril Dodd, Russell Stannard and Harry Tomlinson. In 1958 Cyril spent a year learning bubble chamber physics with Wilson Powell at the University of California at Berkeley, and became the leader of the UCL group, building up both material and human resources. By the mid-1960s it had a staff of 21: four academic staff, three postdoctoral fellows, six PhD students, an electronics engineer, a computer expert and six scanners. This group became involved in a major project – the construction of a heavy liquid bubble chamber commissioned by the National Institute for Research in Nuclear Science (NIRNS) for its site at Harwell, later renamed the Rutherford Appleton Laboratory; Cyril, the senior physicist on the project, described it as “by far the biggest chamber of its type in the country”.

Cyril was a very active member of the UCL climbing club, which made excursions to North Wales, Skye and NW Scotland. In 1957 he met a young lab assistant, Margaret Johnson, in the club and they married in 1959. By 1965 they had three children: Jill, Christine and John. In 1967 Cyril left UCL for Aberdeen University. The move had been spurred by the couple’s mutual love of the outdoors and Aberdeen’s easy accessibility to the mountains for walking and skiing.

Cyril has been described by a colleague at Aberdeen as “a hands-on, practical person”.

As a Senior Lecturer, he became involved in laboratory teaching with the Honours students, and also worked on his book *Cloud and Bubble Chambers*. In the 1970s he joined Aberdeen’s radio astronomy group, bringing with him microwave experience gained at UCL on the microtron project.

Cyril’s whole family were outdoor enthusiasts, and he organised hill walks for his colleagues, their spouses, and students.

In 1986 Margaret was diagnosed with cancer, and died at the beginning of 1987, aged 54. Cyril retired in 1988, but continued part-time until 1990. He remarried in 1995; he and Renee enjoyed 20 years of active life with family and friends in the Lake District and beyond. He died in July 2019.

Jim Grozier and John Reid
with thanks to **John Henderson**



Bryan Lynn

Bryan Lynn, our close friend and colleague who many in the Department knew as Jenny Thomas's husband passed away on 2 May 2020. Bryan made many important contributions to theoretical particle physics, most notably to electroweak precision physics, and worked closely with experimentalists in the days of LEP and SLC. After leaving particle physics he had a successful career in finance. He however continued to engage with theoretical physics research. He became an honorary fellow at UCL (and had visiting appointments at CERN, Texas A&M and Case Western) and discussed and published interesting work calling for new approaches to address most fundamental questions of the Standard Model of particle physics.

Many of us in the HEP group remember Bryan's electrifying personality and many lively discussions about physics, economy, philosophy and the world.

Professor Jonathan Butterworth, a former head of the Physics and Astronomy Department, and a long-term friend and collaborator said:

"I met Bryan through Jenny, although I was already familiar with his renowned work on precision electroweak physics for LEP. Over many years, we argued about physics and finance, and sometimes played music together (he was especially proud of our 'turgid slice of stadium rock' on the ATLAS 'Resonance' CD. The word of choice is 'stadium')."

For a while Susanna, my wife, worked in his group at Merrill Lynch, where he was, and I quote "the best boss I ever had". Since rejoining physics, he was full of original ideas and fiercely productive. He was an amazing guy and it is still hard to accept that he has left us."

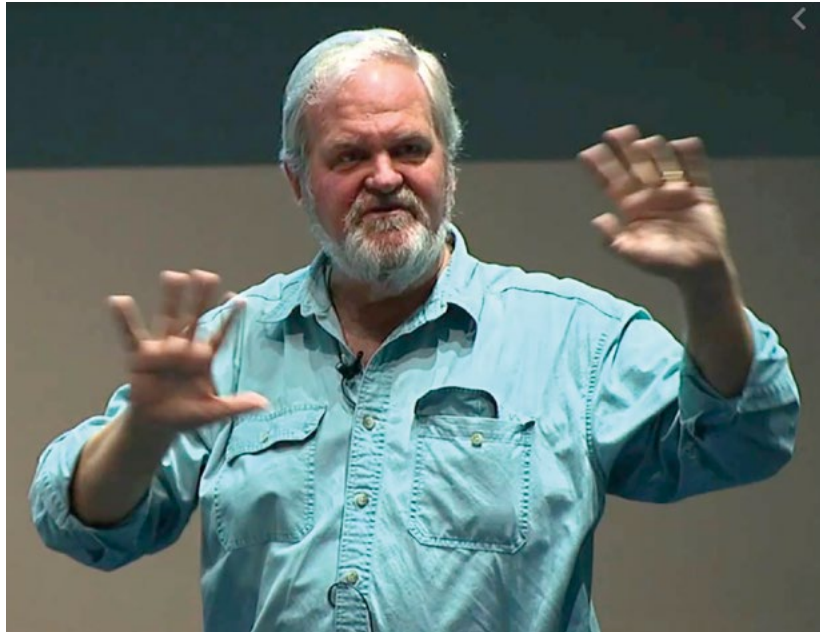

Derek McNally

It is with great sadness that I inform you of the death of Dr Derek McNally. Derek joined UCL as a lecturer in 1960 and became the Director of UCLO (then known as ULO) from 1989 to 1997. His main research interests were in the dynamics of cloud collapse to form stars and the diffuse interstellar bands. Derek was highly engaged in promoting Astronomy and was very involved with the Royal Astronomical Society over the course of many decades, first as a Secretary and then Vice President and Treasurer. Derek also held many prominent roles within the International Astronomical Union (IAU) and was its General Secretary in the late 80s. Derek taught and inspired many who became professional astronomers at institutions all over the world, and even had an asteroid named after him (4326 McNally). Our thoughts are with his family.

Raman Prinja

I first met him in the early 70's when I was appointed as a demonstrator at ULO for a year by Wilson and Massey so I could complete my PhD write up. Obviously I had to do some work for the money. Must have been 1972-3. Dr McNally had a dry sense of humour which took a little getting used to.

As a demonstrator at ULO for the practical observing using the telescopes there (the Radcliffe, the Joynson and the Wilson telescope, none of the 'super-duper' ones that are there now) I came across 3rd year undergraduates. three stick in my mind. Willis, Howarth and Prinja. You all know or knew them. (I apologise for using a 'Trumpism' to mention the new telescopes now at UCLO.)

After I got to know Derek I found him to be always approachable. He could be awkward at times, but who can't. He asked if I could produce an infrared detector system for the Wilson telescope, a reflector telescope.

I got so far in the one year I had at ULO with the electronics and it was finished off later on by project students with the help of others in the IR group. The big drawback was there was no funding for it (so what's new). So it had to be made from what was around in the IR Group and also, a bit of a drawback, it needed liquid Nitrogen to cool the detector. A 25 litre flask of liquid Nitrogen in the back of a car with the windows open, from UCL to MillHill would be a big no-no now. Health and Safety wasn't around. It did work. But it wasn't possible to have it mounted all the time as the teaching on the Wilson telescope was directed towards visible observations.

Years passed as they do and Derek became Director of ULO. I still taught there on occasions. So our paths did cross. At one stage, I think it was just before he retired, I found out he was a bird watcher, as am I. (I won't use the word 'twitcher', I find it demeaning.) It was in the early 90's when we met up again at ULO that I was able to tell him about a holiday trip I had made to the Galapagos Islands! Needless to say he wanted to know all about it and was very envious. Whether he and his wife ever made it there I don't know. He would certainly have appreciated the dark skies there. That was another of his passions which stemmed from astronomy. Bringing awareness to the general community of trying to make changes to keep the skies DARK for astronomical observing.

He was a good person to have known and I'm glad our paths crossed at UCL/UCLO. 'You know all the answers now Derek'. R.I.P. I raise a glass to you.

Ian Furness

We all hated Derek's 'Spherical Astronomy' course as undergrads...although I now find his book a model of clarity.

Ian Howarth



Derek's last visit to UCL (September 2018) was as a guest of honour at the 50th year reunion of undergraduates who attended his and Bill Somerville's astronomy classes. Over the years, Derek trained and enthused many of the world's successful professional astronomers.

Front row L to R: Richard Ellis, Bill Somerville, Derek McNally, Margaret Page (née Thompson), Susan Bound (née French), Keith Mason.

Middle row L to R: Jan Rek, David Love, Phil Charles, Pat Whitelock, Michael Collins, Howard Huckle.

Back row L to R: Ken Phillips, David Carnochan, Richard Swifte.

A Sample of Staff Accolades

Department Teaching Prize

The Physics and Astronomy Departmental Teaching Prize for 2018–19 has been awarded to **Stan Zochowski** for his sustained record of outstanding innovation and excellence in teaching delivery and student support, across the full spectrum of our programmes and modules. Stan's achievements and contributions are too many to list here. But, as an example, last year Stan took on our Year 1 core module "Mathematical Methods 1" PHAS0002, and used video-casts, quizzes and drop-in problems classes and discussion sessions. This approach resulted in excellent student outcomes and satisfaction, across a wide-range of intake backgrounds, accommodating those with and without further mathematics A-level.

Technician of the Year Award

The Physics and Astronomy Departmental Technician of the Year Award for 2018–19 has been awarded to **Derek Attree**.

It is hard to overestimate multiple contributions Derek has provided to the experimental programme of the High Energy Physics (HEP) group in his role of mechanical engineer. Many of the projects could not have initiated or successfully carried forward without his mechanical expertise and hard work. His contributions span over more than 40 years and cover flagship particle physics experiments with UCL involvement and leadership, such as OPAL, ATLAS, MINOS, SuperNEMO and many others.

In the last year Derek continued to provide critically important mechanical engineering support for the group as well as mentoring for junior engineers, PhD students and postdoctoral fellows. Apart from continuing to support major international projects such as DUNE and SuperNEMO, Derek has been instrumental in detector development activities of the group in particular helping to build an apparatus for quality assurance of proton beams used in cancer radiotherapy. Derek's vast experience in mechanical engineering combined with his deep knowledge of UCL including critically important safety matters makes him indispensable for successfully running our 4th year MSci projects — a clear example of the connected curriculum where research and teaching come together. This year in particular Derek's contributions were vital to ensure all experimental projects have run successfully and safely. Derek's wisdom and experience not only deliver day-to-day operational support, but also guide the strategy of the HEP group and provide mentoring to its members.

Göran Gustafsson Prize

Awarded to **Hiranya Peiris**

Hiranya Peiris who has been awarded the 2020 Göran Gustafsson Prize in Physics from the Royal Swedish Academy of Science, "for her innovative research on the dynamics of the early universe, which links cosmological observations to basic physics".

Hiranya Peiris, Professor of Astrophysics at UCL and Director of the Oskar Klein Centre at Stockholm University research interests include the physics of the very early Universe and its origin. With the help of data from the new Vera Rubin Observatory in Chile, she hopes to gain a greater understanding of the fundamental physics that guide the development of the universe – from the beginning to the present.

Equality, Diversity and Inclusion Award

Lia Li is one of five individuals to win a 'Make Space for Inclusion in STEM' award.

In addition to her work using optical whispering gallery mode resonances for sensing motion at the classical/quantum boundary, Lia is a fierce advocate for under-represented groups in physics. She has supported UCL students and staff by running the Women in Physics Group between 2017-2019, introducing career panels, Wikithons with Dr. Jess Wade and Dr. Alice White that increase the representation of women and LGBTQ+ researchers on Wikipedia, and a thank you card for Prof. Jocelyn Bell Burnell for her Special Breakthrough Prize donation to the Institute of Physics.

Lia was nominated for the prize by Madina Wane, a PhD at Imperial. She says "I found out about the awards and Lia's work through Twitter. Lia exemplifies the honesty, dedication, and allyship we need to make STEM a better place for everyone. Seeing Lia's work and commitment recognized makes me optimistic that all the efforts to improve STEM are slowly but surely making a difference. Lia and The STEM Squad have shown me that community is incredibly important if we want to improve STEM for all. Through her work in science communication, entrepreneurship, and advocacy, Lia has shown me that there are many opportunities to improve society as a scientist. Making a positive difference is as much about your work beyond research as it is about your scientific contributions".

Group Faculty Education Award

Selina Lovell, Helen Copeland, Ryan Edmonds, Sadia Begum, Annalisa Medici, Sarah Murphy and Nadia Waller received the Group Faculty Education Award.

The education support team won the Faculty award for their professional support to Physics and Astronomy staff and students, including providing outstanding pastoral advice and support.

The American Institute of Physics Writing for Children prize

The American Institute of Physics has awarded **Professor Raman Prinja**, Head of UCL Physics & Astronomy, a science communication prize for his children's book 'Planetarium'

Since 1968, the American Institute of Physics has recognised journalists, authors, reporters and other diverse writers for their efforts in science communication.

This year, the Writing for Children prize has been awarded to Professor Prinja for his extensively illustrated and far-reaching guide to the universe.

The judging committee emphasised that 'Planetarium' is a book that can provide hours of education and family discussions. The committee was "impressed with the depth of scientific concepts and areas of astronomy covered in the book."

Royal Society book prize

Planetarium: Welcome to the Museum, by **Raman Prinja** and artist **Chris Wormell**, has been chosen by children as the winning book for the 2019 Royal Society's Young People's Book Prize. A record-breaking number of over 10,600 young people drawn from 471 schools and youth groups from across the UK cast their votes for their favourite science book from a shortlist of six titles, chosen by a panel of adult judges, including author Michael Rosen and Royal Society Fellow Professor Sheila Rowan.

The prize, which champions the best science books for under-14s, was awarded at a ceremony hosted by CBBC's Lindsey Russell at the National Science and Media Museum, Bradford, on 13 November 2019.

The Royal Astronomical Society 'Named' Lectures

The Royal Astronomical Society announced the 2020 winners of its medals and prizes for 2020, the bicentenary of its foundation.

The Gerald Whitrow Lecture is given every two years by a distinguished and eloquent speaker on any topic in cosmology, including its philosophy. For 2020, the Gerald Whitrow Lecturer will be Professor Andrew Pontzen.

Given annually by a distinguished and eloquent speaker on a suitable topic in astronomy, Professor Ofer Lahav has been awarded the 2020 George Darwin Lecture.

Finally, the James Dungey Lecturer for 2020 will be Professor Sarah Matthews. The James Dungey Lecture is given annually by a distinguished and eloquent speaker on a suitable topic in geophysics.

Royal Society of Chemistry Awards

Angelos Michaelides has been awarded the Royal Society of Chemistry's Surfaces and Interfaces Award.

Angelos Michaelides received recognition for his research on complex aqueous interfaces and the formation of ice at such interfaces, receiving the Surfaces and Interfaces Award. His work involves the use of high-performance supercomputers to better understand important problems at the interface between chemistry and physics.

The Royal Society of Chemistry's Prizes and Awards are given in recognition of originality and impact of research, or for each winner's contribution to the chemical sciences industry or education. They also acknowledge the importance of teamwork across the chemical sciences, as well as the abilities of individuals to develop successful collaborations.

Mathematical & Physical Sciences Faculty

Vice Dean (International)

Ofer Lahav has been appointed as Vice-Dean (International) for MAPS from April 2020

Ofer Lahav is Perren Chair of Astronomy in the Astrophysics Group at UCL. He is also co-Director of the STFC-funded Centre for Doctoral Training in Data Intensive Science at UCL, established in 2017. Ofer's research area is observational cosmology, in particular probing and characterising dark matter and dark energy. His work involves advanced statistical methods e.g., machine learning for big data.

Vice Dean (Equality, Diversity & Inclusion)

Alexandra Olaya-Castro has been appointed Vice-Dean (Equality, Diversity & Inclusion)

Professor Olaya-Castro is a theoretical physicist and is known for her work on quantum physics on biomolecular processes, specifically for her research on quantum effects in photosynthesis. Before joining UCL, she gained an MSc in Physics from Universidad de Los Andes in Colombia, a PhD from the University of Oxford and did research on quantum optics at California Institute of Technology, and on solid state physics at the Institute of Microstructural Sciences in Ottawa.

Visiting Fellow at All Souls College Oxford for the Hilary and Trinity Terms (January-June 2020).

Ofer Lahav has accepted a Visiting Fellowship for the 2020 – 2021 academic year.

Headline Research

Tensor Networks

Tensor networks are a way of representing quantum states that quantifies the “spooky action at a distance” noticed by Einstein. This property has been understood as the defining property of quantum states that underpins the unusual behaviour of quantum systems and their potential power for alternative methods of computation.

Professor Andrew Green and his group have been developing tensor techniques to obtain a range of fundamental insights about quantum systems and to learn how to harness their properties in near-term intermediate-scale quantum (NISQ) computers. The perspectives provided by tensor networks are expected to lead to many insights and applications in the near future.

A first result relates to a fundamental question that has long vexed physicists: how the classical world emerges from the underlying quantum world. Recent insights have shown that the interplay of chaotic and quantum dynamics plays a fundamental role. The group have used tensor networks to show how this quantum chaos should be formulated and quantified for many-particle quantum states.

They have shown that quantum chaotic systems can be connected to many different classically chaotic systems, which in turn can be subject to the classical tools of dynamical analysis. Further work shows how tensor networks can be used as a framework for programming quantum computers. This applies to both the use of quantum computers for machine learning tasks and as a general framework for simulating the dynamics of certain types of quantum system.

Tensor networks offer a way forward to address the theoretical challenge of quantum computing, an inspiring objective of modern physics. As Richard Feynman put it, “nature isn’t classical, dammit, and if you want to make a simulation of nature, you’d better make it quantum mechanical, and by golly it’s a wonderful problem, because it doesn’t look so easy.”

References

The Lyapunov Spectra of Quantum Thermalisation Hallam et al Nature Communications 10, 2708 (2019); Hierarchical quantum classifiers Grant et al njp Quantum Information 4, 65, (2018); Parallel Quantum Simulation on Small Quantum Computers Barratt et al., ArXiv:2003.12087

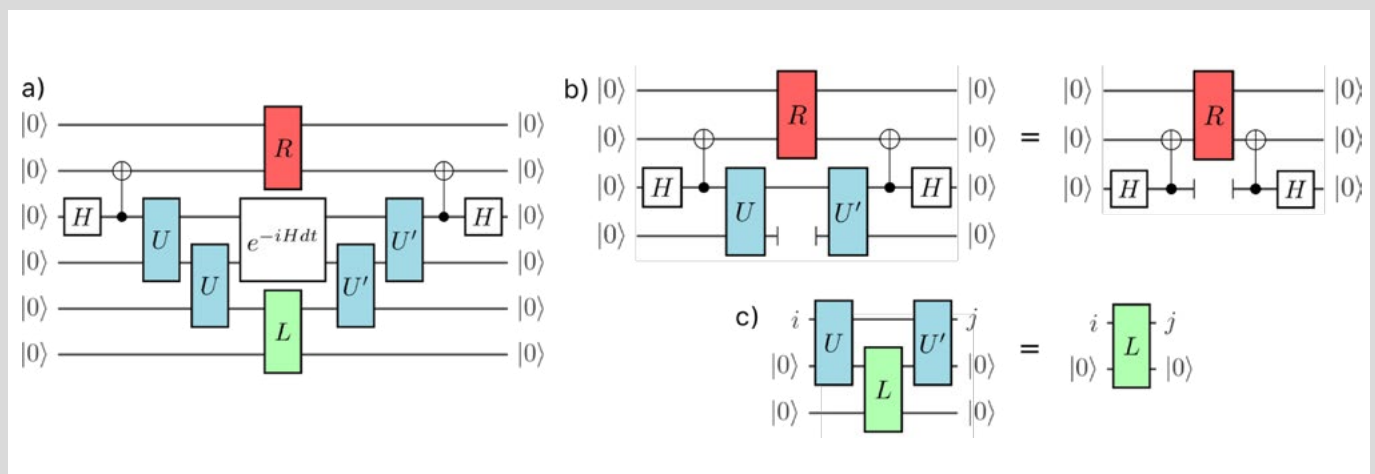

Picture of a quantum circuit



Research Spotlight

High Energy Physics (HEP)

High energy physics (HEP) is about looking at extremely small sizes, or equivalently, at extremely high energies. Its aim is to explore the underlying nature and foundations of the entire physical universe, as well as the forces and laws that govern its development.

As one of the largest particle physics groups in the country our research at UCL HEP covers a wide range of areas, from theoretical physics studies and exploring the world's highest energy proton-proton collisions at the Large Hadron Collider (LHC) to looking at mysteries of neutrinos, searching for elusive dark matter, exploring new physics with precision muon studies and many more. In addition to fundamental physics research we are involved in a number of interdisciplinary and knowledge exchange projects (see "Quality Assurance for Proton Beam Therapy" below) and are active in promoting particle physics in schools and among general public.

In the past year the group has continued to attract young and diverse talent. Dr. Rebecca Chislett started in October 2019 as new Lecturer and is leading UCL effort in $g-2$ and $Mu3e$ experiments that are searching for signs of new physics through precise studies of muons at the Fermi National Laboratory (FNAL) in Illinois, USA. Dr. Matteo Agostini won a prestigious Ernst Rutherford Fellowship and started at UCL in July 2020 working on the LEGEND neutrinoless double beta decay experiment. Technical and engineering design capabilities of the group have been strengthened with the arrival of a new junior mechanical engineer, Connor Godden, in February 2020.

The COVID-19 outbreak, the subsequent campus closure and travel restrictions have inevitably made an impact on such a highly collaborative and intrinsically international branch of science as particle physics. On the other hand, precisely because of its international nature particle physicists are very accustomed to remote collaboration and regularly use advanced video and other communication tools in their work. The remote work period since March 2020 has therefore been very productive with lots of analyses completed, papers published, and large international conferences and workshops successfully conducted.

Here we provide a few highlights from 2019-20. More information on the UCL HEP group activities can be found at:

<http://www.hep.ucl.ac.uk/research.shtml>

Quantum Technologies for Fundamental Physics and Neutrino Mass

The UCL HEP group played a key role in establishing a new interdisciplinary initiative at a national level – Quantum Technologies for Fundamental Physics (QTFP). The goal is to use recent breakthroughs in quantum sensors and quantum computing to address particle physics questions. This novel way of doing particle physics is highly complementary to the traditional HEP "toolkit" such as accelerators, underground laboratories and particle detectors. It has the potential to revolutionise particle physics experimental research making the seemingly impossible measurements possible. A new funding call of ca. £40M was announced by UKRI for projects that can bring fundamental physics and quantum technologies together. A large number of exciting proposals to use these technologies for searching dark matter, gravitational waves, neutrino mass and understanding quantum mechanics fundamentals have been submitted.

The UCL HEP group led a proposal for using quantum technologies to measure the absolute neutrino mass – a holy grail of particle physics and a long-standing goal of many experiments. The novel approach would involve investigating the beta decay of atomic tritium, ^3H , brought to a standstill inside a sophisticated atomic trap, and measuring the energy of emitted electrons with quantum electronics. The project will bring together an unusually diverse range of experts: HEP and AMOPP groups at UCL and Warwick, quantum electronics experts from Cambridge and NPL, electronics engineers from the University of Swansea. As this Annual Review goes to press, we have just received the news that this proposal has been funded opening a new page in our research activity.

LHC and beyond

LHC successfully completed their two science runs at the end of 2018 delivering an integrated luminosity of over 150 fb^{-1} , or over 10^{16} proton-proton collisions at a record centre-of-mass energy of 13 TeV with an average rate of a billion collisions per second. The accelerator complex is currently in a long shutdown for planned upgrades and LHC will start its Run 3 in February 2022 and will run until the end of 2024 collecting a similar luminosity of Run 1+2. Another long shutdown will follow to prepare LHC for a major upgrade, so called High-Luminosity LHC (HL-LHC), which will be ready for data taking in 2027.

The UCL HEP group is heavily involved in ATLAS, one of the two general purpose detectors at LHC. Our researchers lead a number of flagship physics analyses as well as software and hardware upgrades necessary for HL-LHC. In

particular, we led the analysis of the Higgs boson decaying to b-quarks ($H \rightarrow b\bar{b}$) using a jet substructure technique pioneered at UCL by Prof. Jonathan Butterworth over a decade ago. The new results in the $H \rightarrow b\bar{b}$ obtained in the past year is a big step in our understanding of the Higgs boson allowing us to move on from the discovery phase to measuring and understanding the property of this new particle type, which could help answer many of the outstanding questions about the Universe.

The past year has been very important for defining the future path of particle physics in Europe and the world. Projects of the scale of LHC require strategic thinking and painstaking planning decades before these complex and very expensive machines are switched on. Following almost two years of discussion and deliberation the CERN council announced on 19 June 2020 an updated strategy that will guide the future of particle physics in Europe. Among key recommendations is the statement that an electron-positron Higgs factory should be the highest priority next collider after the LHC. For the longer term, European particle physics has the ambition to operate a proton-proton collider at the highest achievable energy, around 100 TeV or higher. A possible pathway toward this goal is building a new 100 km circular tunnel infrastructure around CERN which can be used to host initially an e+e- collider and then to be upgraded to a hadron collider (so called Future Circular Collider, FCC-ee and FCC-hh). Prof. Jon Butterworth of UCL was the UK representative in the European Strategy Group charged with drafting the strategy proposal.

Quality Assurance for Proton Beam Therapy

Technologies developed for particle physics have found many “real life” applications. This is especially true in medicine where particle detectors and novel software methods are used for diagnostic and therapeutic purposes. The UCL group developed a novel method for measuring the range of proton beams in human tissue used for cancer treatment. Such a quality assurance measurement is a legal requirement for all proton beam therapy centres.

We developed and prototyped a Quality Assurance Range Calorimeter (QuARC) based on plastic scintillator originally developed at UCL for the SuperNEMO experiment and read out by a large-scale CMOS sensor. The detector has been tested at clinical beams in a radiotherapy centre in Heidelberg (Germany) and at the Clatterbridge Cancer Centre in the UK. The tests showed an outstanding performance of the proton range reconstruction with an accuracy of $< 0.4\text{mm}$ in a matter of seconds beating commercial analogues that are currently used.

The QuARC was also used to explore, for the first time, a novel online treatment monitoring technique in carbon beam therapy using a mixed helium/carbon beam convincingly showing the feasibility of the method (see Figure 1).

Further work is underway to bring this device to clinical trials with the ambitious aim to equip all proton therapy centres with it (starting perhaps with the UCLH proton beam therapy centre which will soon open its doors to patients). The UK Patent Application No. 1914654.7 was prepared in close cooperation with UCLB and filed on 10 October 2019.

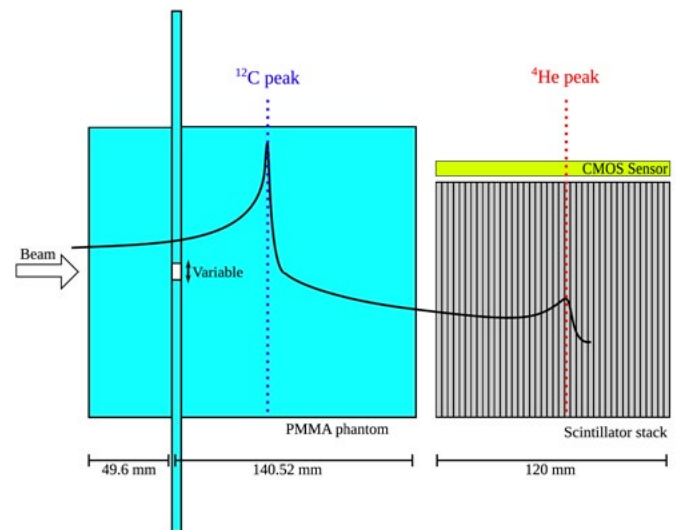

Figure 1 Schematic diagram of the QuARC setup used to investigate the feasibility of an online monitoring technology during treatment with helium and carbon ions. Two PMMA slabs of equal thickness were used to create a vertical slit of variable width/thickness in the setup simulating small changes in patient's position and conditions. The test demonstrated that even small $\sim\text{mm}$ scale changes such as bowel gas movements can be detected in vivo and thus the treatment adjusted.

Neutrino Physics and Dark Matter

The group has a longstanding tradition of initiating and leading international experiments exploring new physics with neutrinos and searching for dark matter. In the past year we have made significant contributions to neutrino oscillation experiments (NOvA, DUNE, MINOS+) and neutrinoless double beta decay experiments (SuperNEMO, LEGEND).

Figure 2 shows the inside of a DUNE prototype detector, ProtoDUNE, that has been operating at CERN. The UCL group has built and commissioned two liquid argon (LAr) purity monitors that provide daily measurements of electronegative impurities in LAr at a level of 1 part in 1010, which is critically important for DUNE operation.

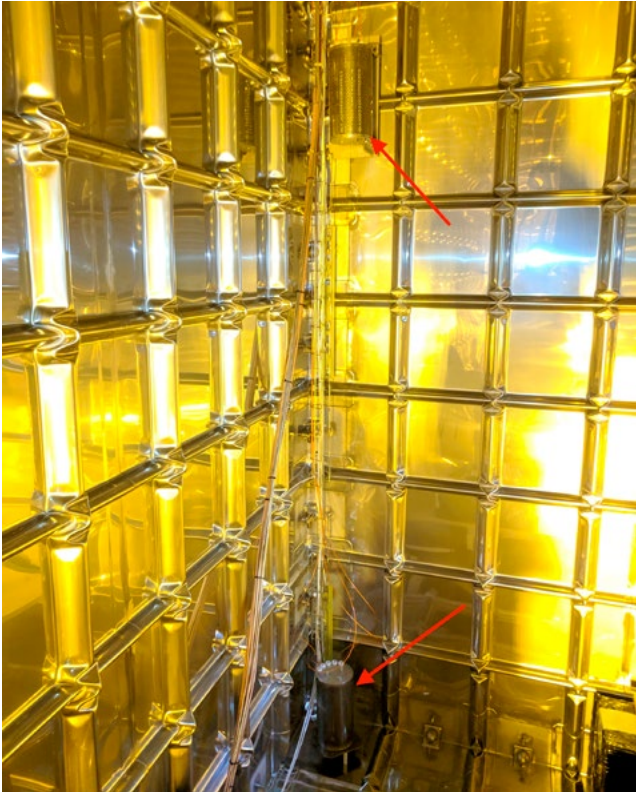

Figure 2. Inside the ProtoDUNE-DP (Dual Phase) detector at CERN. The active detector volume is 6x6x6 m³ containing 300 tonnes of liquid argon (LAr). The arrows are pointing at two LAr purity monitors that have been developed, built and commissioned by UCL HEP team members.

MINOS+ presented the neutrino oscillation results at the NEUTRINO-2020 conference for the full data set which includes 3 years of running at higher peak energy (7 GeV).

The higher energy region has now been well explored by MINOS+ and the precision measurement of the oscillation shape is in good agreement with the hypothesis of three flavour mixing with the parameters now well defined. MINOS+ has also set world beating limits on the presence of sterile neutrinos by searching for anomalous neutrino disappearance over the long 735km baseline from the neutrino source, using both Near and Far detectors. Using the two detectors and insisting upon self-consistent behaviour in both provides a very stringent test on the existence of these popular yet as-yet-undiscovered candidates for dark matter and beyond the Standard-Model physics.

We are also key players in the LZ international collaboration. The goal of LZ is to search for dark matter using a large quantity of liquid Xenon in an ultra-low background detector located in a deep underground laboratory in South Dakota, USA. The UCL group was instrumental in achieving a major milestone: the detector transportation 4850 feet underground into the Davis Campus of the SURF underground laboratory in October 2019 (see Figure 3). First physics results are expected in 2021 and are eagerly awaited by the international community.

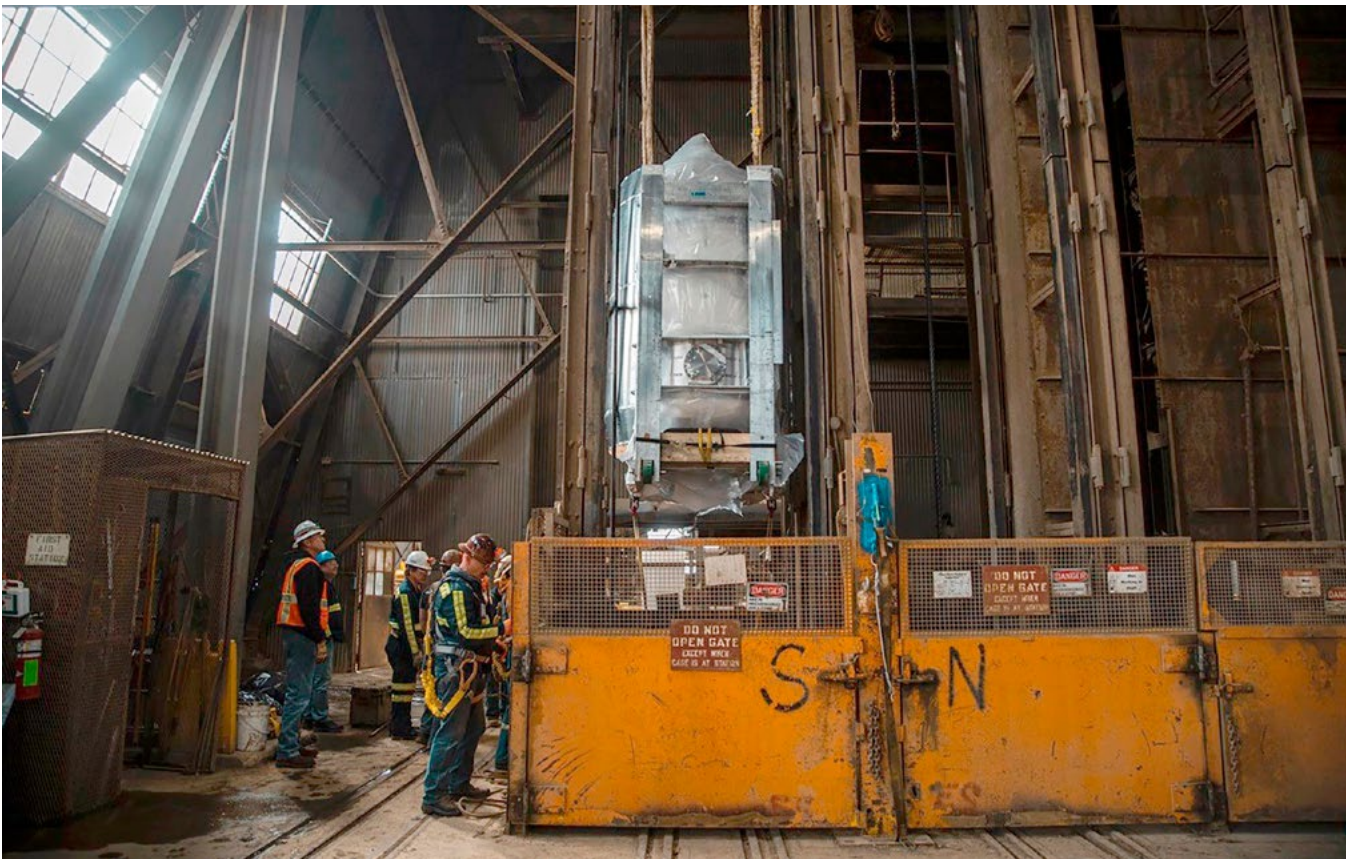

Figure 3. A \$100M LZ central detector initiating its nearly mile-long descent down an elevator shaft, and its delivery to a research cavern where it will hunt for dark matter. Credit: Nick Hubbard, Sanford Underground Research Facility.

Astrophysics – Studies of Alien Worlds

The 2019 Nobel Prize for Physics was shared by Michel Mayor and Didier Queloz for their 1995 discovery of a planet orbiting the star 51 Pegasus. In the intervening years astronomers have identified over 4000 of these extrasolar planets or exoplanets, and demonstrated that such planets are ubiquitous meaning that we should expect practically all stars to support planetary systems. These observations have thrown up many surprises in the form of Jupiter-like planets orbiting close to their host star, large numbers “super-Earth” planets which are rocky but decidedly larger than Earth and hot “lava planets” which orbit so close their host star that their rocky surface must be molten. Of course there is also huge interest in finding planets which have the potential to support life. Observational constraints mean that so-far planets orbiting in the so-called habitable (or Goldilocks) zone, where it should be possible to find liquid water on planet’s surface, have only been detected orbiting close to stars which are much smaller and hence cooler than our Sun.

Of course given this plethora of planets and their fascinating and unexpected variety, it is natural to ask what each of these planets is made of. Characterising exoplanets is therefore a major research goal and one in which astrophysicists at UCL are playing a leading role in. As discussed below characterising these faint, indeed largely unseen, objects require ingenuity, state-of-the-art observational facilities, detailed models of the planet and in particular of its atmosphere, and large quantities of laboratory data on how possible atmospheric species absorb light.

UCL has expertise in all these aspects; in 2019 a team comprising Dr Angelos Tsiaras, Dr Ingo Waldmann, Prof Giovanna Tinetti, Prof Jonathan Tennyson, and Prof Sergey Yurchenko pooled their expertise to make the first detection of water in the atmosphere of an exoplanet, called K2-18b, which orbits its host star at a distance which places it in the habitable zone, see Figures 1 and 2. This observation became UCL’s most reported news story with some 4000 worldwide media reports!



Figure 1. Artist’s impression of K2-18b (ESA/Hubble, M. Kornmesser). K2-18b is the exoplanet known to have both water and temperatures that could support life. The planet is eight times the mass of Earth. It orbits the cool dwarf star K2-18, which is about 110 light years from Earth in the Leo constellation. <https://sci.esa.int/web/hubble/-/exoplanet-k2-18b-artist-s-impression->

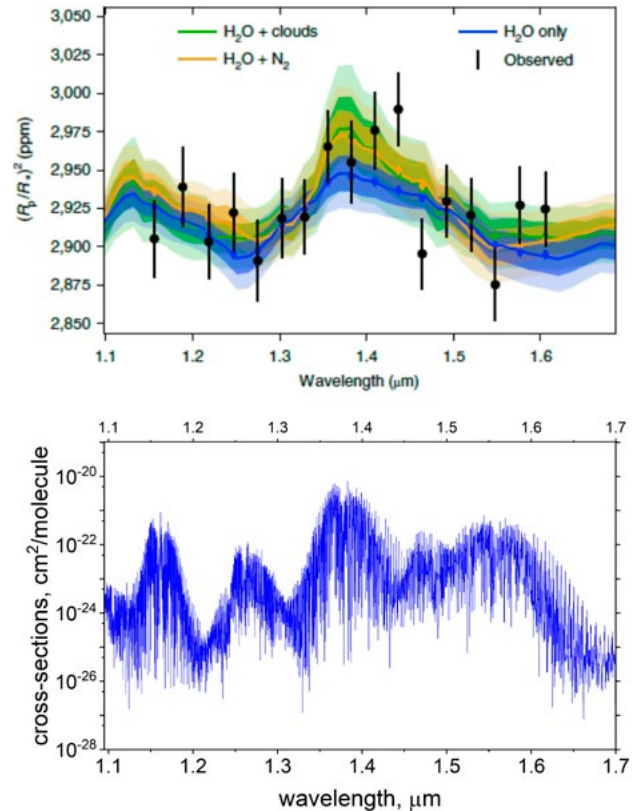

Figure 2. Top: A transmission of the atmosphere of K2-18b, observation vs simulations. The observations are by the ESA/NASA Hubble Space Telescope (2016 and 2017); the simulations of the starlight filtered through K2-18b’s atmosphere performed with open-source algorithms by Ingo Waldmann’s team show a cloud-free atmosphere containing only H₂O and H₂-He (blue), a cloud free atmosphere containing H₂O, H₂-He and N₂ (orange) and a cloudy atmosphere containing only H₂O and H₂-He (green). Bottom: a higher resolution spectrum of water (296 K) in all complexity computed using state-of-the-art computational tools developed by ExoMol. Copyright 2020, reproduced with permission from “Springer Nature”.

The observational data used by Tsiaras and co-workers were recorded using the Hubble Space Telescope. Hubble was launched prior to the detection of the first exoplanet and hence not really designed for studies of their atmospheres. The study of K2-18b therefore yielded a tantalizing glimpse of the planet but left nearly all other questions unanswered. Addressing these issues will require telescopes designed for and dedicated to the characterisation of exoplanetary atmospheres. As detailed in the 2019 annual review, Prof. Giovanna Tinetti (Fig. 4) is Principal Investigator of the European Space Agency’s Atmospheric Remote-sensing Infrared Exoplanet Large-survey (Ariel) satellite which is due to launch in 2028. Ariel will look particularly at those exoplanets which, when viewed by us, pass in front of their stars. This transiting behaviour allows the detailed analysis of how the light from the host star is modified by the exoplanet’s atmosphere which is recorded simply as the effective size of the atmosphere at different wavelengths as shown in Figure 2.

Ariel, see Figure 3, will study about 1000 exoplanets at a large range of “colours” spanning much of the infrared and visible spectrum. These observations will provide valuable insight in the chemical composition of these planets and should provide the first steps in categorising planets into different families. In what is something of theme for this work, Prof. Tinetti’s work has been extensively supported by the European Research Council (ERC) under her project ExoLights: Decoding Lights from Exotic World.



Figure 3. Artists impression of the Ariel Space Telescope. Ariel is an exoplanet characterisation mission which will observe star light as an exoplanet passes in front and behind its host stars over wide range of infrared and visible wavelengths using a 1 m telescope. Ariel is a European Space Agency mission led by Givoanna Tinetti (UCL) which is scheduled for launch in 2028. Credit: ARIEL Consortium.

As a companion to Ariel Prof Tinetti, along with Prof Jonathan Tennyson and Prof Giorgio Savini, have been working on the Twinkle Space Mission. Twinkle is a proposed commercial exoplanet characterisation mission being managed by UCL start-up company Blue Skies Space Ltd (BSSL) which is currently going through its mission definition stages in collaboration with Airbus UK. The aim is to launch Twinkle in three years supported by revenues provided by researchers’ subscriptions for access to its observations. The Science as a Service model of astronomical observation is new and offers significant advantages in terms of cost, speed and agility compared to the more traditional space agency model.

The interpretation of observations of exoplanetary atmospheres is far from straightforward. To do so requires the building of atmospheric models which represent the many possible physical processes occurring there and how they affect starlight as it travels through them. Dr Ingo Waldmann (Fig. 4) and his group have developed a sophisticated code TauREx (Tau Retrieval for Exoplanets) which models the way the starlight passes through the exoplanetary atmosphere. In general, given the limited observations data available, there are many possible solutions to this problem and TauREx using sophisticated (Bayesian) statistics to guide solutions to the problem. More recently Dr Waldmann has pioneered the use of machine learning and deep learning for the data analysis and interpretation of exoplanetary observations as part of the ERC-funded project ExoAI: Deciphering super-Earths using Artificial Intelligence.



Figure 4. Dr. Ingo Waldmann has pioneered the use of artificial intelligence and deep learning for analysis of exoplanetary atmospheres. Ingo is leader of the ExoAI ERC project and developer of τ -Rex an open access, efficient, retrieval code for exoplanetary atmospheres which is based about the use of ExoMol data.

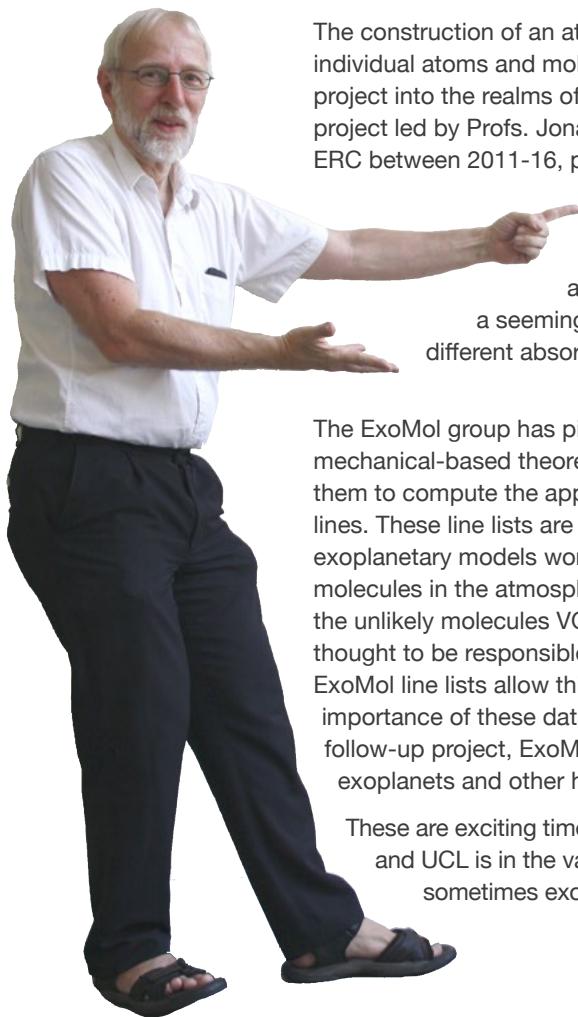

The construction of an atmospheric model requires significant input on the behaviour of the individual atoms and molecules which comprise this atmosphere. Obtaining these data takes the project into the realms of atom and molecular physics, and quantum mechanics. The ExoMol project led by Profs. Jonathan Tennyson (Fig. 5) and Sergey Yurchenko (Fig. 6), and funded by the ERC between 2011-16, provides comprehensive datasets of how key molecules which are likely to exist in the atmospheres of exoplanets absorb and emit light of different colours. Because the atmospheres of most observable exoplanets are rather hot (often well over 1000 K) the list of wavelengths where a particular molecule may absorb light can become huge. Thus for even a seemingly simple molecule like methane consideration of more than 10 billion different absorption lines can be necessary.

The ExoMol group has pioneered quantum mechanical-based theoretical procedures which allow them to compute the appropriate lists of absorption lines. These line lists are used by TauREx, and indeed exoplanetary models world-wide, to model the behaviour of molecules in the atmospheres of exoplanets (Fig. 7). For example the unlikely molecules VO (vanadium oxide) and TiO (titanium oxide) are thought to be responsible for the greenhouse effect in hot Jupiter exoplanets; ExoMol line lists allow this effect to be modelled. The demand for and importance of these data is so intense that the ERC have just funded a follow-up project, ExoMolHD: Precision spectroscopic data for studies of exoplanets and other hot atmospheres which will run from 2020 to 2025.

These are exciting times in the young science of exoplanet studies and UCL is in the vanguard of studying these remote, exciting and sometimes exotic bodies.

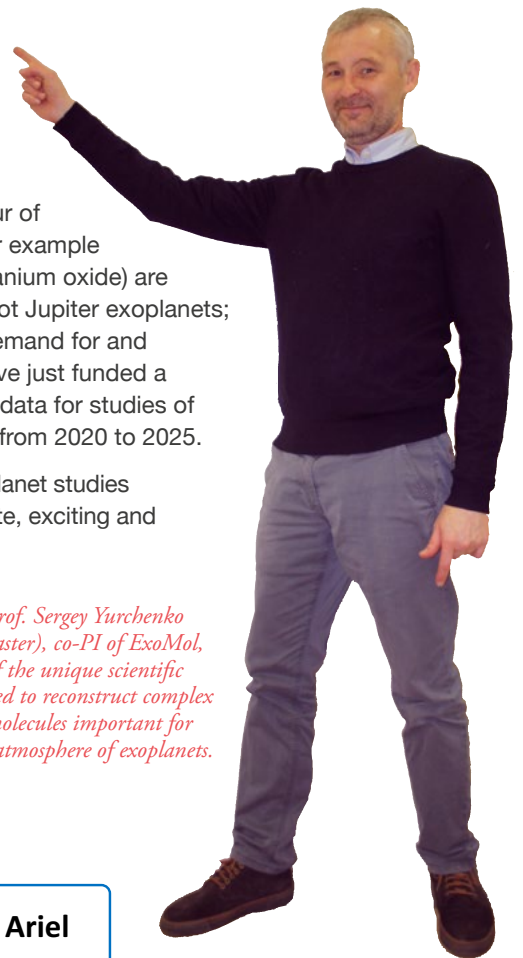

Figure 5. Prof. Jonathan Tennyson, FRS is Massey Professor of Physics at UCL, Founder of ExoMol and PI of the ERC funded projects ExoMolHD.

Prof. Tennyson is an expert in the accurate treatment of quantum mechanical processes involving small molecules including electron-molecule scattering, nuclear motion and electronic structure of molecules. He has written a book Astronomical Spectroscopy.

Figure 6. Prof. Sergey Yurchenko (@TroveMaster), co-PI of ExoMol, developer of the unique scientific software used to reconstruct complex spectra of molecules important for analysis of atmosphere of exoplanets.

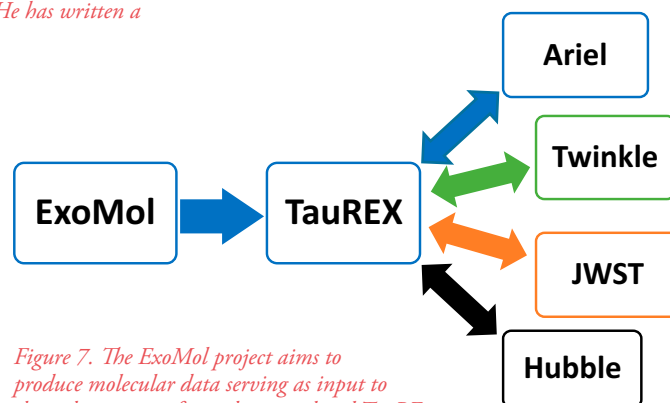

Figure 7. The ExoMol project aims to produce molecular data serving as input to the radiative transfer and retrieval tool TauREx, which in turn is used to analyse observations from space telescopes and helps to guide current and future missions.

Biological Physics (BioP)

The Biological Physics group focuses on solving key intellectual and practical problems in the physics of biological systems and the underlying properties of soft matter, from molecular to cellular length scales, by using experimental, computational and theoretical methods. It overlaps with the cross-faculty UCL Institute for the Physics of Living Systems (IPLS), which promotes interdisciplinary approaches that combine physics and biology to understand fundamental properties of living systems. Several of its activities focus on membranes and their role in compartmentalising living matter, as described below.

Biological membranes – walls with moving bricks

In the Harry Potter books and films, Harry gains access to Diagon Alley by tapping the correct brick in the wall behind the Leaky Cauldron pub (from the trash can, three up and two across). As if by magic – it is magic, of course – the bricks in the wall start to move and rearrange, to next open up the entrance to the wizarding world's shopping delights.

Similar magic is essential to compartmentalise life at the (sub)micron scale. Molecular brick walls surround the cells in our body, protecting them from the outside world; surround the nucleus in the cell, separating genetic information from machinery that may grind it to pieces; surround mitochondria, which may be considered as the power plants of our cells; and so on. These walls are called membranes and the bricks are fatty molecules called lipids.

“...lipids can exist in different phases, ranging from completely static or solid, to much more dynamic, liquid phases.”

Just like the bricks in the wall at the entry of Diagon Alley, lipids can exist in different phases, ranging from completely static or solid, to much more dynamic, liquid phases. Moreover, they can undergo phase transitions, like ice transitioning to water from one phase to another. Intriguingly, depending on the membrane composition, lipids can phase-separate into different membrane domains that are all fluid, yet differ in being enriched by different lipid species with different levels of order. From the entropic perspective, it is most advantageous to completely mix

these species together, as is the case at higher temperatures. Yet below a certain temperature, the lipids can undergo a liquid-demixing transition resulting into separate liquid-ordered and liquid-disordered domains in the membrane.

The mystery of the immune synapse

There has been a lot of speculation about the role of lipid membrane domains in how signals are communicated across membranes in biology. Such domain formation has been demonstrated in the context of immune killing: the targeting of virus-infected and cancerous cells by some types of white blood cells. Once the immune system recognised such rogue cells, it directs these white blood cells towards them, after which the white blood cell forms a close contact – the so-called immune synapse – with its target.

Once the immune synapse is formed, the white blood cell secretes rather toxic molecules called granzymes into the space between the white blood cell and its target. To facilitate entry of these molecules into the target cell, this is complemented by the presence of perforin, a protein that can form oligomeric pores into a membrane, perforating the membrane, allowing the granzymes to cross the membrane. These white blood cells operate as serial killers, eliminating one target after the other, while invariably escaping unscathed. An obvious question has long been what protected the white blood cells from the lethal molecules they secrete.

Although this question was first raised decades ago, its answer was less obvious. Although there were early reports that perforin binds less effectively to lipid membranes that are more tightly packed or ordered, others searched for specific inhibitor molecules that might be present at the white blood cell surface, so far without any conclusive success.

From molecular assembly pathways to membrane physics

Initially unbothered by this question, Bart Hoogenboom's team has long been interested in how individual perforin molecules land on the membrane, next somehow get together and form assemblies that slice holes in the membrane. To understand this, they visualised perforin pore formation on model membranes, i.e., membranes that were synthetically assembled from pure lipids, with the lipids chosen to provide a reasonable mimetic of the cell membrane. In doing so, they pulled various tricks, including that of deliberately inducing the formation of lipid domains to corral the perforin on the

membrane, making it less mobile and therewith easier to resolve. This led to the observation that perforin preferentially binds to more disordered liquid lipid domains, and that more ordered, tighter pack lipid domains appeared resistant to perforin binding.

This triggered a whole set of new experiments, in collaboration with Iliia Voskoboinik's lab at the Peter MacCallum Cancer Centre in Melbourne, to investigate if such a resistance could play a role in protecting white blood cells from perforin, thus preventing them from committing suicide every time they kill a target. By modulating the lipid order in the membranes of live white blood cells, they showed that enhanced lipid order indeed reduces perforin binding. Yet, somewhat troubling, when the cells were next exposed to larger amounts of perforin, they could bind perforin in similar amounts as other cells, yet in contrast to these other cells, the white blood cells still did not die.

Searching for other candidate lipids to play a role in protecting white blood cells from perforin, PhD student Adrian Hodel identified several negatively charged lipids, prepared model membranes including these lipids, and next demonstrated that the inclusion of these negative lipids did not prevent perforin binding to the membrane, but caused it to collapse in a dysfunctional, non-perforating state. And again, this was found to be consistent with observations on real white blood cells, where non-lethal perforin was found to co-localise with negatively charged lipids on the cell surface.

“...next steps will involve the study of similar mechanisms in the context of cancer.”

Outlook

In the white blood cell membrane facing the immune synapse, we see an accumulation of more ordered lipid domains as well as the externalisation of negatively charged lipids. Relating this to perforin, the UCL and Melbourne teams could show that this is what protects white blood cells from the deadly molecular weapons they secrete. Initiated by very basic questions about how perforin assembles on a membrane, next steps will involve the study of similar mechanisms in the context of cancer. Various cancer cells have been reported to have enhanced lipid order and/or to have enhanced negative charge on their surface. Hence the big and clinically important question is if this protects cancer cells from perforin and if this plays a role in the resistance of tumours against various cancer immunotherapies.

References

- [1] Leung, Hodel, et al. (2017), *Nature Nanotechnology* 12, 467, <http://dx.doi.org/10.1038/nnano.2016.303>
- [2] Rudd-Schmidt, Hodel, et al. (2019), *Nature Communications* 10, 5396, <http://dx.doi.org/10.1038/s41467-019-13385-x>

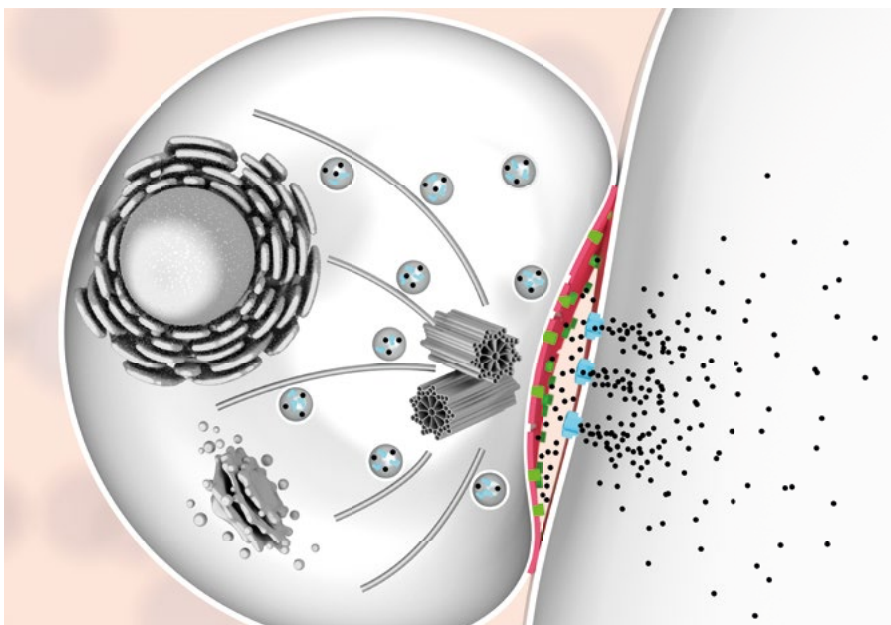

Schematic of a cytotoxic lymphocyte (type of white blood cell) forming an immune synapse, with granzymes (black dots) entering the target cells through perforin pores (light blue) in the target cell membrane. High lipid order domains (red) and exposed negatively charged lipids (green) at the immunological synapse protect the white blood cell against the perforin it secretes.

Atomic, Molecular, Optical and Positron Physics (AMOPP)

The research activities in the Atomic Molecular Optical and Positron Physics (AMOPP) Group span one of the widest ranges of AMO physics in any physics department in the UK. We currently have 18 academic staff, 5 technical and support staff, 27 research fellows and postdoctoral researchers, and 56 PhD students. Our academic staff hold active research grants as principal investigators with a total value in excess of £10.4M. At present there are formal links between researchers in the AMOPP group and all other research groups within the department.

Low-energy antimatter physics

In the area of low-energy antimatter physics we have significant activities in experimental studies involving positrons and positronium atoms. These include work on positron and positronium scattering led by Prof Gaetana Laricchia, and laser and microwave spectroscopy of excited positronium atoms for tests of antimatter gravity and bound-state quantum electrodynamics led by Prof David Cassidy. New results in this area reported over the last year include: Measurements of differential positronium-formation cross sections in low-energy collisions of positrons with rare gas atoms. Related work on angle-resolved electron scattering from water molecules at scattering angles close to zero degrees. The demonstration of a new approach to guiding neutral positronium atoms prepared in long-lived highly-excited states – known as Rydberg states – using inhomogeneous electric fields (see Figure 1). And the observation of resonant shifts in the energy level structure of positronium atoms when they interact at short range with MgO nanocrystals.

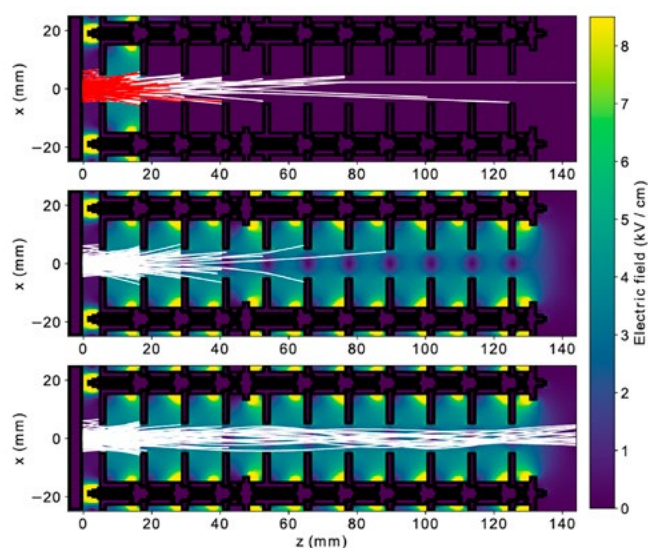

Figure 1 Calculated trajectories of positronium atoms in their short-lived ground state (red) and long-lived Rydberg states with different electric dipole moments (white) in an electrostatic guide.

Theoretical quantum optics and quantum information processing

Work in theoretical quantum optics and quantum information processing includes activities in quantum information theory, quantum computation, quantum simulation, quantum communication, quantum sensing, quantum gravity and blackholes, quantum thermodynamics and foundations of quantum mechanics. The people working on these topics are Prof Sougato Bose, Prof Dan Browne, Prof Tania Monteiro, Prof Jonathan Oppenheim and Prof Alessio Serafini. Over the last year results reported in these areas include investigations of the manipulation of entanglement between quantum bits (qubits) and light, and the use of entanglement as a resource to perform tasks. Studies have also been reported on the limitations that arise when cooling quantum systems by exploiting interactions with their environment, and on quantum computing architectures and classical simulation algorithms for quantum circuits. Work has also been carried out on dynamical methods for quantum-state-selective control over baths of nuclear spins with applications in quantum sensing, and on quantum sensing and cooling of levitated nanoparticles in optomechanical systems.

Theoretical work on collective quantum dynamics in light-matter systems is led by Prof Marzena Szymanska and lies at the boundary between the AMOPP and CMMP groups. Recent results in this area include the observation and characterisation of quantum fluids of light in semiconductor micro cavities. Prof Szymanska was recently awarded an EPSRC Fellowship extension to support her work on ‘Far from Equilibrium Quantum Simulators’.

Quantum interfaces and quantum sensing

Experimental work on quantum interfaces and quantum sensing is carried out in the laboratories of Prof Stephen Hogan and Prof Ferruccio Renzoni. Recent work in Prof Hogan’s group on the development of hybrid approaches to quantum information processing has led to the first demonstration of a coherent interface between neutral atoms in highly-excited Rydberg states and microwave fields in superconducting resonators integrated into chip-based circuits (see Figure 2). This hybrid system is of interest in the interconversion of optical and microwave photons for quantum communication, and in the development of long-coherence-time quantum memories. Prof Renzoni’s group exploit atoms as high-sensitivity quantum sensors to measure and image magnetic fields. These atomic magnetometers are of interest in material characterisation, biomedical imaging, and for security and surveillance. This year’s Carey Foster Prize for outstanding postgraduate physics research in AMOPP was awarded to Dr Cameron Deans from Prof Renzoni’s group for his PhD thesis entitled *Electromagnetic Induction Imaging with Atomic Magnetometers*.

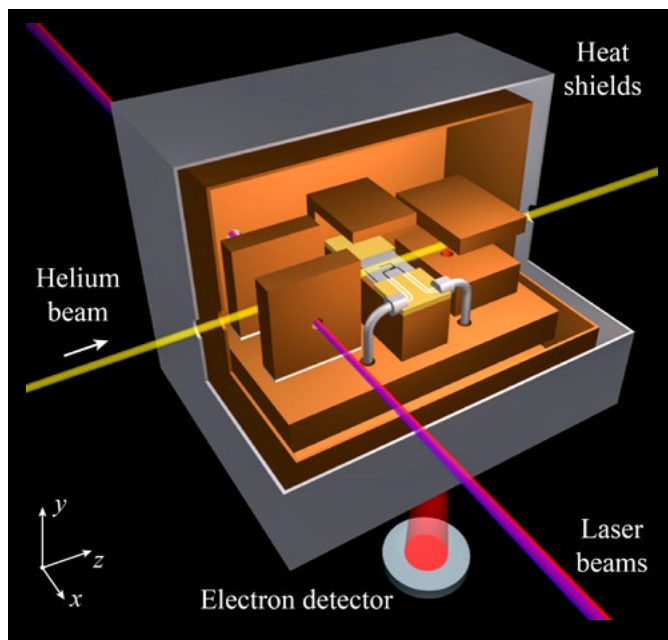

Figure 2 Cryogenic apparatus used to demonstrate a hybrid quantum interface between gas-phase Rydberg atoms and solid-state superconducting microwave circuits.

Cavity optomechanics with levitated nanoparticles

Experiments in the area of cavity optomechanics with levitated nanoparticles are led by Prof Peter Barker and range from the development of quantum-limited optomechanical sensors for measuring forces, to tests of fundamental physics through studies of the collapse of spatial superposition states of heavy particles. Recent results reported in this area include the characterisation of a charged levitated nanomechanical oscillator, the implementation of super-resolution imaging techniques for levitated nanoparticles, the identification of new schemes for the characterisation of noise in quantum systems, and the evaluation of experimental approaches to detect wavefunction collapse for levitated particles in spatial superposition states.

Atoms and molecules in strong and short-wavelength laser fields

Theoretical work on atoms and molecules in strong and short-wavelength laser fields reported over the last year has included: Studies of electron dynamics in double ionisation of atoms in strong few- cycle and single-cycle laser pulses, and enhanced double ionisation of the two-electron D3+ molecular cation in circularly polarised laser fields led by Prof Agapi Emmanouilidou. And investigations of effects of quantum interference and nonclassicality that lead to

enhanced ionisation of molecules in strong laser fields, and work on ultrafast holographic photoelectron imaging led by Prof Carla Figueira de Morrison Faria.

Theoretical molecular physics and spectroscopy

In the area of theoretical molecular physics and spectroscopy Prof Jonathan Tennyson and Prof Sergey Yurchenko lead research efforts that encompass calculations of molecular spectra at high temperatures, and scattering cross-sections for collisions involving atoms, molecules and electrons in environments ranging from ultracold gases to high temperature plasmas. They also study rotation induced chirality in small molecules, and work on identifying molecules suitable for testing fundamental physics, for example, through searches for time-variations of the proton-to-electron mass ratio. Prof Tennyson and Prof Yurchenko have strong connections with extrasolar planet (exoplanet) research in the Astrophysics group that recently resulted in the identification of water vapour in spectra of the atmosphere of habitable zone exoplanet with a mass eight times that of Earth. This year Prof Tennyson was, for the second time, awarded a prestigious Advanced Grant from the European Research Council. This grant will support his work on *Precision spectroscopic data for studies of exoplanets and other hot atmospheres*.

Optical biophysics

The optical biophysics research activities that take place in the AMOPP group are directly connected with research in the BioP group. They include: Experimental work on biophysical interactions and sensing in the laboratory of Dr Isabel Llorente-Garcia which is directed toward studies of virus entry into living cells. Experimental studies of resonant energy transfer in biological molecules led by Prof Angus Bain. And theoretical work on effects of quantum coherence in biomolecular energy transfer processes led by Prof Alexandra Olaya-Castro. Recent results in these areas include the development of new methods to produce ellipsoidal magnetic microparticles for use as sensors or actuators in lab-on-a-chip applications, studies of photoactivation of reactive oxygen species for therapeutic applications, and theoretical work on the relation between quantum coherence and synchronisation in electronic energy transfer in biomolecules which is mediated by coherent interactions with intramolecular vibrational modes. In the last year Prof Alexandra Olaya-Castro was awarded a prestigious grant from the Gordon and Betty Moore Foundation to support her work on *Revealing Unambiguous Signatures of Quantum Coherence in Photosynthetic Complexes on a Photonic Chip*.

Condensed Matter and Material Physics (CMMP)

The Condensed Matter and Materials Physics (CMMP) has twenty-one permanent academic staff who research the physics and materials science of solids, liquids and other condensed matter states. Key research themes in the group include materials modelling, many body theory, neutron and X-ray scattering and materials discovery.

This year, Professor Dorothy Duffy has retired, but we have welcomed Dr. Roger Johnson, previously a Research Fellow at Oxford, who begins a Lectureship. Dr. Johnson is a significant user of the ISIS Neutron and Muon Source and the Diamond Light Source where he conducts neutron and X-ray scattering experiments. These experiments are designed to probe the structure-property relationships in quantum materials, including magneto-orbital systems, quantum magnets and multiferroics.

The following describe some highlights of work in the group published over the last year.

Laser induced melt-front dynamics

The transition from solid to liquid, otherwise known as melting, is a fundamental process of condensed matter that remains to be fully understood in microscopic terms. Professor Ian Robinson and collaborators from the USA and Korea used time-resolved X-ray diffraction to examine the ultrafast melting of polycrystalline gold thin films. The experiments involved a pump-probe technique whereby an optical laser pump was followed by a delayed hard X-ray pulse. An intermediate new diffraction peak was observed, which was attributed to material trapped between the solid and melted states. This forms 50 picoseconds after laser excitation and persists beyond 500 picoseconds, the peak width initially growing rapidly and then later narrowing. These effects were attributed to a melting band originating from the grain boundaries and propagating into the grains (Figure 1). The observation of the intermediate state shows the importance to the melting process of internal grain boundaries and will have implications on the use of ultrafast lasers for ablation during pulsed laser deposition (a technique for growing crystalline films).

Reference: T. Assefa, et al., Ultrafast X-ray Diffraction Study of Melt-front Dynamics in Polycrystalline Thin Films, *Science Advances*, 6, eaax2445 (2020).

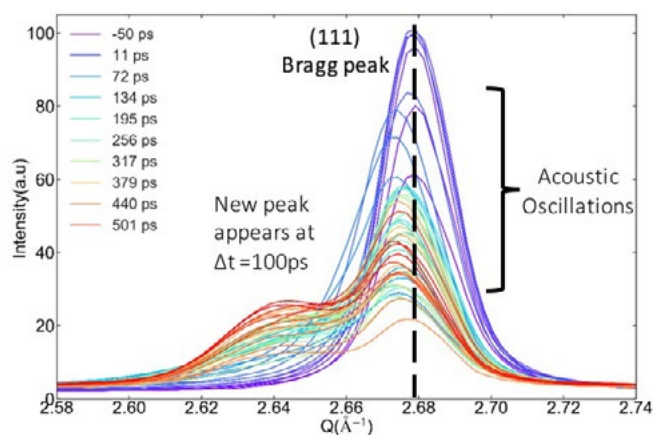

Figure 1. Time evolution of an x-ray peak during melting

Localisation versus delocalization of chargecarriers

Wave-particle duality is one of the most famous features of quantum mechanics. In pure metals, electrical conductivity relies on the wave like properties of electrons, whereas in many doped oxides it is associated with the particle-nature of electrons. But in certain semiconducting materials made of organic molecules neither picture applies.

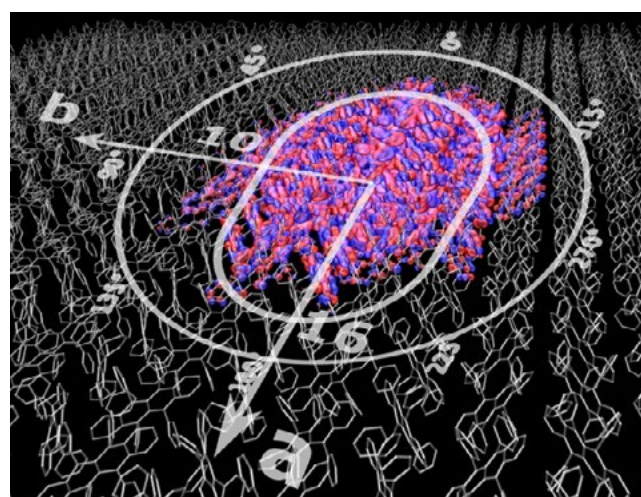

Figure 2. Simulated snapshot of an electron-hole polaron in crystalline rubrene

In a recent numerical study published in *Nature Communications*, Dr. Jochen Blumberger and his group concluded that in some of these materials electrons form ‘flickering polarons’, objects that are ‘half way’ between waves and particles. They are delocalized over up to 10–20 molecules in the most conductive organic crystals and constantly change their shape and extension under the influence of the thermal motion of the atoms. This unexpected result, obtained by advanced non-adiabatic molecular dynamics simulation was supported by experimental charge mobility measurements and electron paramagnetic resonance data. This new physical picture fills a gap left by traditional transport models which assume purely wavelike or particle-like properties (Figure 2).

Reference: S. Giannini, et al., Quantum localization and delocalization of charge carriers in organic semiconducting crystals, *Nature Comm.*, 10, 3843, 2019.

New Types of Energy Storage

Dr. Chris Howard has collaborated with Chinese scientists and colleagues from UCL Chemistry to create a new graphene-based bendable supercapacitor, which may show potential as a portable power supply in technology. The material, described in *Nature Energy*, can bend up to 180 degrees (Figure 3) without significantly diminishing in capacity, suggesting possible applications in bendy phones or wearable electronics. The capacitor uses flexible graphene electrodes sandwiching a gel-like conducting medium.

Reference: Tuning the interlayer spacing of graphene laminate films for efficient pore utilization towards compact capacitive energy storage, Z. Li et al., *Nature Energy* 5, 160 (2020).

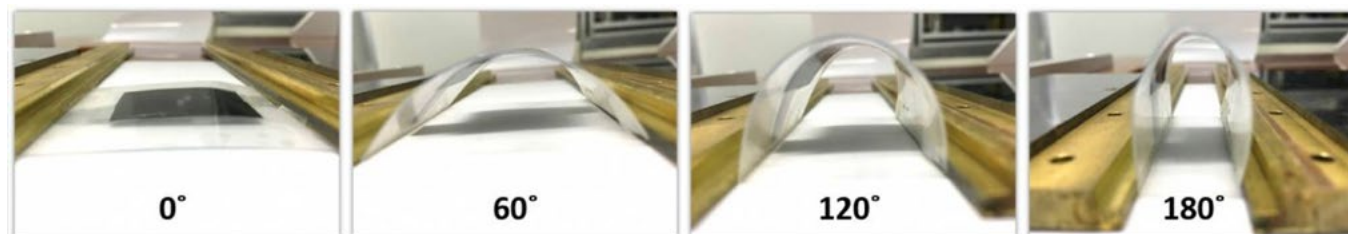

Figure 3. Bendable capacitor

Organic data transfer

The demand for faster data transmission speeds is driving the popularity of light-emitting devices in visible light communication systems. Prof. Franco Cacialli has collaborated with an international team involving researchers from Newcastle, Poland and Italy, to develop faster visible light communication based on organic light-emitting diodes. The scientists created new organic light emitting diodes that achieved the fastest-ever data speed for such systems: 2.2 megabytes per second. Described in the journal *Nature Light*, the new systems create opportunities for new ‘internet-of-things’ connectivity, as well as wearable and implantable biosensors technology.

Reference: A. Minotto et al., Communication with efficient far-red/near-infrared polymer light-emitting diodes. *Light Sci. App.*9, 70 (2020).

Quantum tunnelling of magnetic monopoles

Spin Ice is an unusual low-temperature magnetic state that supports ‘magnetic monopole’ excitations. These can be thought of as tiny atom-sized packets of magnetic charge or pole density that are free to migrate within a sample, though not pass through its boundaries. Within this constraint, the monopole can mediate a transient or AC magnetic analogue of electricity, which has aroused great interest. In experimental work published in *Nature Communications*, Prof Steve Bramwell and his collaborators from Grenoble (France) and Cardiff showed how the monopoles actually move. In fact they quantum mechanically tunnel from site to site in the spin ice lattice and the tunnelling is assisted by nuclear spins that help to bring the electronic levels associated with the monopoles on neighbouring sites to resonance.

Reference: C. Paulsen et al., *Nature Communications* 10:1509 (2019).



Research Statistics

Research Statistics

Active Grants and Contracts

In the last financial year (Aug 2018 – Jul 2019), the MAPS faculty as a whole yielded £48.7 million, with the Department of Physics and Astronomy contributing £13.1 million (26%) of the total research income for the MAPS faculty.

Physics and Astronomy

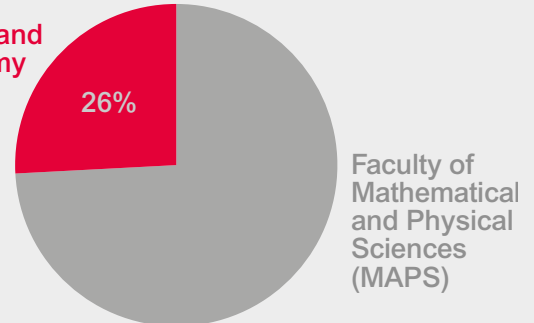

Astrophysics (Astro)

EUROPLANET 2020 Research Infrastructure – EPN2020-RI, (European Commission), PI: Dr Nick Achilleos, £193,839

MSSL Solar and Planetary Physics Consolidated Grant 2016-2019, (STFC), PI: Dr Nick Achilleos, £392,682

Solar System Consolidated Grant 2019-22, (STFC), PI: Dr Nick Achilleos, £457,240

EPN-2024-RI, (European Commission), PI: Dr Nick Achilleos, £47,400

Time-variability of the ionospheric electric field: solar wind driving and atmospheric, (NERC), PI: Dr Anasuya Aruliah, £88,611

Developing ALFA and NEAT for JWST data, (STFC), PI: Prof Michael Barlow, £49,893

SNDUST: Supernova Dust: Production and Survival Rates, (European Commission), PI: Prof Michael Barlow, £2,076,614

Additive manufacturing of CubeSat mirrors, (UK SPACE AGENCY), PI: Dr David Brooks, £9,694

The origin of cosmic dust in galaxies, (STFC), PI: Dr Ilse De Looze, £512,669

The Dark Energy Spectroscopic Instrument, (STFC), PI: Prof Peter Doel, £742,939

Early Star-Forming Galaxies and Cosmic Reionisation, (European Commission), PI: Prof Richard Ellis, £2,017,280

Support for DESI-UK Observers 2019 Dec – 2020 Feb, (STFC), PI: Dr Jay Farihi, £25,202

UCL Astrophysics Consolidated Grant 2018-2021, (STFC), PI: Dr Jay Farihi, £332,067

Towards new physics from next-generation cosmological data, (Royal Society), PI: Dr Stephen Martin Feeney, £572,894

Fellowship Dr Andreu Font-Ribera: Precision Cosmology at High Redshift with the Lyman-Alpha Forest, (STFC), PI: Dr Andreu Font Ribera, £491,529

DiRAC 2.5y Bridging Funding – UCL, (STFC), PI: Dr Clare Elizabeth Jenner, £156,599

DiRAC-3 Operations 2019-2022 – UCL, (STFC), PI: Dr Clare Elizabeth Jenner, £812,851

EUCLID Implementation Phase 2015 2020, (STFC), PI: Dr Benjamin Joachimi, £654,666

Euclid UK SGS Bridging Grant- UCL, (UK SPACE AGENCY), PI: Dr Benjamin Joachimi, £315,115

Newton Fund for capacity building in data intensive science in the Middle-East, (STFC), PI: Prof Ofer Lahav, £303,213

UCL Astrophysics Consolidated Grant 2018-2021, (STFC), PI: Prof Ofer Lahav, £460,325

Deep learning dark matter halo formation, (Universities Research Association INC), PI: Dr Hiranya Peiris, £8,621

Consolidating leadership in a new approach to galaxy formation, (Royal Society), PI: Prof Andrew Pontzen, £199,912

Understanding the Hubble sequence, (Royal Society), PI: Prof Andrew Pontzen, £327,649

UCL Astrophysics Consolidated Grant 2018-2021, (STFC), PI: Prof Andrew Pontzen, £129,713

Towards new physics from next-generation cosmological data, (STFC), PI: Prof Andrew Pontzen, £519,699

Understanding the diversity of galaxy morphology in the era of large spectroscopic surveys, (European Commission), PI: Prof Andrew Pontzen, £1,392,984

Cold gas as a probe of galaxy evolution: the dust connection, (Royal Society), PI: Dr Amelie Saintonge, £198,933

Cold gas as a probe of galaxy evolution: multi-phase outflows at high resolution, (Royal Society), PI: Dr Amelie Saintonge, £95,992

Cold gas as a probe of galaxy evolution, (Royal Society), PI: Dr Amelie Saintonge, £352,853

PRISTINE design: a space mission to measure high accuracy deviations from the uniform black-body spectrum, (Royal Society), PI: Prof Giorgio Savini, £11,700

Distributed Pipelines for Networks of Robotic Telescopes, (Konica Minolta Business Solutions Europe GMBH), PI: Prof Giorgio Savini, £36,000

ARIEL Science Advisory Team UK Activities, (STFC), PI: Prof Giovanna Tinetti, £50,477

ARIEL space mission Phase B, (UK Space Agency), PI: Prof Giovanna Tinetti, £214,993

Exoplanet Atmosphere New Emission Transmission Spectra Analysis, (European Commission), PI: Prof Giovanna Tinetti, £181,700

The Interstellar Medium and Star Formation in Extreme Galactic Environments, (Royal Society), PI: Prof Serena Viti, £12,000

UCL Astrophysics Consolidated Grant 2018-2021, (STFC), PI: Prof Serena Viti, £15,632

AstroChemical Origins, (European Commission), PI: Prof Serena Viti, £450,516

ExoAI: Deciphering super-Earths using Artificial Intelligence, (European Commission), PI: Dr Ingo Waldmann, £1,216,239

DiRAC 2.5y – Networks and Data Management, (STFC), PI: Dr Jeremy Yates, £316,000

DiRAC2.5 Operations: The DiRAC Project Office 2017-2020, (STFC), PI: Dr Jeremy Yates, £216,428

Studentship De Ceuster: Accelerated 3D General Purpose Radiative Transfer Codes, (Intel Corporation UK LTD), PI: Dr Jeremy Yates, £27,144

Using switches to control clusters and data flows, (Mellanox Technologies LTD), PI: Dr Jeremy Yates, £48,136

Computer vision and machine learning for pattern recognition in LHC data, (Lenovo Technology (UTD KINGDOM)), PI: Dr Jeremy Yates, £48,500

Atomic, Molecular, Optical and Positron Physics (AMOPP)

New Approaches to Studying Redox Metabolism Using Time-Resolved NAD(P) H Fluorescence and Anisotropy, (BBSRC), PI: Prof Angus Bain, £296,382

Impact Acceleration Account – University College London 2017, (EPSRC), PI: Prof Peter Barker, £9,490

Quantum Cavity Optomechanics of Levitated Nanoparticles: Foundations to Technologies, (EPSRC), PI: Prof Peter Barker, £869,905

Testing the Large-Scale Limit for Future Quantum Technologies, (European Commission), PI: Prof Peter Barker, £415,197

Laser refrigeration on the nanoscale: From nanocryostats to quantum optomechanics, (EPSRC), PI: Prof Peter Barker, £729,667

Levitated Quantum Gyroscopes, (Royal Society), PI: Prof Sougato Bose, £3,000

Non-Ergodic Quantum Manipulation, (EPSRC), PI: Prof Sougato Bose, £570,713

Quantum Code Design and Architecture, (EPSRC), PI: Dr Dan Browne, £246,719

Prosperity Partnership in Quantum Software for Modeling and Simulation, (EPSRC), PI: Dr Dan Browne, £308,579

Quantum Computing and Simulation Hub, (EPSRC), PI: Dr Dan Browne, £252,643

Control and Spectroscopy of Excited States of Positronium, (EPSRC), PI: Prof David Cassidy, £802,355

Production of positronium atoms, ions, and molecules, (EPSRC), PI: Prof David Cassidy, £853,721

Semi Classical Models for Ultra Fast Multi Electron Phenomena in Intense Electro Magnetic Laser Fields, (EPSRC), PI: Prof Agapi Emmanouilidou, £336,665

Exotic forms of matter in molecules driven by Free-Electron Lasers, (Leverhulme Trust), PI: Prof Agapi Emmanouilidou, £180,939

AQuA DIP: Advanced Quantum Approaches to Double Ionisation Processes, (EPSRC), PI: Prof Carla Figueira De Morisson Faria, £388,202

Catmolchip: Cold Atmospheric Molecules on a Chip, (European Commission), PI: Prof Stephen Hogan, £1,557,183

Interference and Resonant Phenomena Involving Antimatter, (EPSRC), PI: Prof Gaetana Laricchia, £560,729

Optomechanical sensors: rapid prototyping for navigation and quantum technologies, (Royal Academy of Engineering), PI: Dr Ying Lia Li, £198,855

Direct probing of molecular interactions relevant to virus entry via force spectroscopy with optical tweezers in live cells, (EPSRC), PI: Dr Isabel Lorente Garcia, £91,041

Scrambling of Quantum Information in Many-Body Systems, (EPSRC), PI: Dr Lluís Meruelo Masanes, £809,237

Revealing unambiguous signatures of quantum coherence in photosynthetic complexes on a photonic chip, (Gordon and Betty Moore Foundation), PI: Prof Alexandra Olaya-Castro, £493,406

Quantum information applied to fundamental physics, (EPSRC), PI: Prof Jonathan Oppenheim, £623,081

Lead Princeton Uni: IT from QUBIT: Quantum Fields, Gravity and Information, (Simons Foundation), PI: Prof Jonathan Oppenheim, £473,651

Magnetic Induction Tomography with Optical Sensors, (EPSRC), PI: Prof Ferruccio Renzoni, £55,997

Quantum Sensors for Magnetic Induction Tomography of the Heart, (EPSRC), PI: Prof Ferruccio Renzoni, £454,182

Single-shot screening for security applications, (Defence Science and Technology Laboratory), PI: Prof Ferruccio Renzoni, £27,834

Vehicle Checkpoint with Atomic Magnetometers – Phase II, (Defence Science and Technology Laboratory), PI: Prof Ferruccio Renzoni, £223,676

Atomic magnetometers for NMR and NQR sensing of illicit materials, (Defence Science and Technology Laboratory), PI: Prof Ferruccio Renzoni, £64,200

Coherent Gamma Rays from BEC of ¹³⁵mCs isomer, (Atomic Weapons Establishment), PI: Prof Ferruccio Renzoni, £29,612

Polariton lattices: a solid-state platform for quantum simulations of correlated and topological states, (EPSRC), PI: Prof Marzena Szymanska, £116,174

Far From Equilibrium Quantum Simulators, (EPSRC), PI: Prof Marzena Szymanska, £850,350

Electron initiated chemistry: dissociative attachment of small molecules, (Royal Society), PI: Prof Jonathan Tennyson, £2,500

Detailed models of technological plasmas, (Quantemol LTD), PI: Prof Jonathan Tennyson, £23,000

Integrated software for electron-molecule collisions, (STFC), PI: Prof Jonathan Tennyson, £322,353

Short wavelength absorption by water vapour, (NERC), PI: Prof Jonathan Tennyson, £272,984

Electron impact vibrational excitation of molecules, (Quantemol LTD), PI: Prof Jonathan Tennyson, £23,000

Towards quantum-based realisations of the pascal, (European Commission), PI: Prof Jonathan Tennyson, £56,000

UK Atomic, Molecular and Optical physics R-matrix consortium (UK AMOR), (EPSRC), PI: Prof Jonathan Tennyson, £368,071

UCL Astrophysics Consolidated Grant 2018-2021, (STFC), PI: Prof Sergey Yurchenko, £371,077

Quantum processes assisted with machine learning: application and development, (Moscow Witte University), PI: Prof Sergey Yurchenko, £132,277

Condensed Matter & Materials Physics (CMMP)

Softcharge: Charge Carrier Transport in Soft Matter: from Fundamentals to High-Performance Materials, (European Commission), PI: Prof Jochen Blumberger, £1,617,175

Advancing first principles computational modelling of electron transfer processes at molecule/electrode interfaces, (Pacific Northwest National Laboratory), PI: Prof Jochen Blumberger, £6,034

Synchronics Supramolecularly Engineered Architectures for Optoelectronics and Photonics: A Multi-Site Initial Training Action, (European Commission), PI: Prof Franco Cacialli, £802,338

Fellowship Franco Cacialli: Semiconducting Nanostructures, (Royal Society), PI: Prof Franco Cacialli, £62,500

Centre for Advanced Materials for Integrated Energy Systems (CAM – IES), (EPSRC), PI: Prof Franco Cacialli, £83,733

Multifunctional Polymer Light-Emitting Diodes with Visible Light Communications (MARVEL), (EPSRC), PI: Prof Franco Cacialli, £372,355

TOMCAT: Theory of Mantle, Core and Technological Materials, (European Commission), PI: Prof Ronald Cohen, £826,477

Fellowship Eberhardt: Nature Versus Nurture: The Effect of Stellar Irradiation on Atmospheric Evolution, (Royal Astronomical Society), PI: Dr Jo Eberhardt, £165,219

Impact Acceleration Account – University College London 2017, (EPSRC), PI: Dr Chris Howard, £97,551

Graphene Flagship Core Project 2, (European Commission), PI: Dr Chris Howard, £15,330

Spin physics in Two-Dimensional Layered Ferromagnets, (EPSRC), PI: Dr Chris Howard, £36,755

Graphene Flagship Core Project 3, (European Commission), PI: Dr Chris Howard, £29,709

Domain Switching in Multifunctional Materials: Towards a Multiferroic Memory, (Royal Society), PI: Dr Roger Douglas Johnson, £136,959

Materials and Molecular Modelling High Performance (HPC) HUB, (OCF PLC), PI: Prof Angelos Michaelides, £140,000

Tier 2 Hub in Materials And Molecular Modelling, (EPSRC), PI: Prof Angelos Michaelides, £4,000,000

To develop BP's digital lab for upstream oil and gas chemical science, (Knowledge Transfer Partnerships), PI: Prof Angelos Michaelides, £118,313

To develop BP's digital lab for upstream oil and gas chemical science, (BP Exploration Operating Company LTD.), PI: Prof Angelos Michaelides, £163,153

The Materials and Molecular Modelling Hub, (EPSRC), PI: Prof Angelos Michaelides, £4,510,208

Correlated Non-Equilibrium Quantum Matter: Fundamentals and Applications to Nanoscale Systems, (European Commission), PI: Dr Arijet Pal, £1,196,382

Exploring Polaronic Effects in Oxides Using Range-Separated Hybrid Density Functional Theory, (Weizman Institute of Science), PI: Prof Alexander Shluger, £7,059

Understanding and Controlling Dynamic Functional Oxides, (Leverhulme Trust), PI: Prof Alexander Shluger, £147,817

Structural dynamics of amorphous functional oxides – the role of morphology and, (EPSRC), PI: Prof Alexander Shluger, £338,952

Studentship Jakobsen: Adsorption Self-Assembly, (University Of Hamburg), PI: Prof Alexander Shluger, £32,000

Studentship: Atomistic Modeling of Reliability Limiting Point Defects in Silicon Carbide and Near the Interface to Silicon Dioxide or Contacting Metals, (Infineon Technologies Austria AG), PI: Prof Alexander Shluger, £35,000

Surface and Interface Toolkit for the Materials Chemistry Community, (EPSRC), PI: Prof Alexander Shluger, £91,390

Defect Functionalized Sustainable Energy Materials: From Design to Devices Application, (EPSRC), PI: Prof Alexander Shluger, £470,811

Molecular dynamics simulation of interface structure of interface structure and interface diffusion phenomena for the Cu/TiW system, (Infineon Technologies Austria AG), PI: Prof Alexander Shluger, £40,000

Studentship David Ingram: Regeneration of H₂ Storage Materials, (Cella Energy Limited), PI: Prof Neal Skipper, £36,000

Uncovering hidden phases of metal-amine solutions: glasses to superconductors, (Leverhulme Trust), PI: Prof Neal Skipper, £191,579

Materials and Molecular Modelling Exascale Design and Development Working Group, (EPSRC), PI: Miss Karen Stoneham, £3,701

Studentship Edoardo Maria Zatterin: Probing the Static and Dynamic Properties Of Nanoscale Ferroelectric Domains, (European Synchrotron Radiation Facility), PI: Dr Pavlo Zubko, £45,475

FNR – Fundamentals of Negative Capacitance: Towards New Low Power Electronics, (EPSRC), PI: Dr Pavlo Zubko, £464,861

Materials for Neuromorphic Circuits, (European Commission), PI: Dr Pavlo Zubko, £219,210

High Energy Physics (HEP)

Maximizing NOvA physics potential with test beam measurements, (Royal Society), PI: Dr Chris Backhouse, £99,209

Towards leptonic CP violation with NOvA and T2K, (Royal Society), PI: Dr Chris Backhouse, £110,231

Unlocking Neutrino Mysteries with the NOvA and DUNE Experiments, (Royal Society), PI: Dr Chris Backhouse, £508,256

Fellowship Rikkert Hendrik Frederix: Event Simulation for The Large Hardon Collider at High Precision, (STFC), PI: Prof Jonathan Butterworth, £428,325

CJBBW Fellowship Izaskun Jimenez-Serra: Massive Star Formation with New Generation Interferometers, (STFC), PI: Prof Jonathan Butterworth, £451,297

MCnetITN3: Innovative Network for Monte Carlo Event Generators for LHC Physics, (European Commission), PI: Prof Jonathan Butterworth, £290,252

Unlocking neutrino mysteries with the NOvA and DUNE experiments, (STFC), PI: Prof Jonathan Butterworth, £0

Development of the DUNE neutrino observatory, (Royal Society), PI: Prof Mario Campanelli, £5,000

MUSE: Muon Campus in US and Europe Contribution, (European Commission), PI: Dr Rebecca Chislett, £135,000

A Proposal to Extend the Sensitivity to Charged Lepton Flavour Violation by 4 Orders Of Magnitude, (STFC), PI: Dr Rebecca Chislett, £64,887

South-Eastern Particle Theory Alliance Sussex – RHUL – UCL 2017-2020, UCL NODE, (STFC), PI: Dr Frank Deppisch, £119,786

Widening the search for Dark Matter and Physics beyond the Standard Model with direct detection experiments, (STFC), PI: Dr Jim Dobson, £511,341

Fellowship Facini: Searches for Beyond the Standard Model Physics with Hadronic Topologies, (STFC), PI: Dr Gabriel Facini, £489,070

The LUX-ZEPLIN (LZ) Dark Matter Search, (STFC), PI: Prof Chamkaur Ghag, £377,011

XENON Futures: R&D for a Global Rare Event Observatory – Phase 1, (STFC), PI: Prof Chamkaur Ghag, £117,773

UCL Experimental Particle Physics Consolidated Grant (2019-2022), (STFC), PI: Prof Chamkaur Ghag, £3,629,307

UCL Experimental Particle Physics Consolidated Grant (2019-2022), (STFC), PI: Prof Chamkaur Ghag, £79,608

UCL Experimental Particle Physics Consolidated Grant (2019-2022), (STFC), PI: Prof Chamkaur Ghag, £76,149

Spanning multi-TeV to GeV scales for collider discoveries and measurements, (European Commission), PI: Dr Keith Hamilton, £277,764

Extending the sensitivity to charged lepton flavour violation by 4 orders of magnitude with the Mu3e experiment, (Royal Society), PI: Dr Gavin Grant Hesketh, £37,698

Mu3e: a proposal to extend the sensitivity to charged lepton flavour violation by 4 orders of magnitude, (STFC), PI: Dr Gavin Grant Hesketh, £4,536

OMA: Optimization of Medical Accelerators, (European Commission), PI: Dr Simon Jolly, £224,853

Developing Quality Assurance Tools for Proton Beam Therapy, (STFC), PI: Dr Simon Jolly, £304,453

ATLAS Phase-2 Upgrades – Construction project, (STFC), PI: Prof Nikolaos Konstantinidis, £970,302

The Muon g-2 Experiment, (Universities Research Association INC), PI: Prof Mark Lancaster, £10,345

DUNE: Pre-Construction Phase, (STFC), PI: Dr Ryan Nichol, £85,677

UCL Experimental Particle Physics Consolidated Grant (2015–2019), (STFC), PI: Dr Ryan Nichol, £168,981

UCL Experimental Particle Physics Consolidated Grant (2015–2019), (STFC), PI: Dr Ryan Nichol, £4,453,751

UCL Experimental Particle Physics Consolidated Grant (2015–2019), (STFC), PI: Dr Ryan Nichol, £240,849

DUNE Construction Grant, (STFC), PI: Dr Ryan Nichol, £350,947

A Novel Technique to Search for Dark Matter at the Large Hadron Collider, (Leverhulme Trust), PI: Prof Emily Nurse, £288,386

Searching for Dark Matter at the LHC, (Royal Society), PI: Prof Emily Nurse, £84,444

Fellowship: Emily Nurse Higgs Studies and a Search for Dark Matter at the ATLAS Experiment, (Royal Society), PI: Prof Emily Nurse, £274,703

Enhancing H->bb: Exploring the Higgs Sector and Discovering New Physics, (Royal Society), PI: Dr Tim Scanlon, £199,796

Exploring the Higgs Sector and Probing for New Physics using H->bb, (Royal Society), PI: Dr Tim Scanlon, £338,042

The Path to Cp Violation in the Neutrino Sector: Mega-Ton Water Detectors, (Leverhulme Trust), PI: Prof Jennifer Thomas, £383,431

Chromium Chromium, (European Commission), PI: Prof Jennifer Thomas, £2,146,848

Peering at Neutrino Oscillations with a Magnifier, (Royal Society), PI: Prof Jennifer Thomas, £1,126,535

Particle Phenomenology, QCD and the Standard Model, (STFC), PI: Prof Robert Thorne, £435,388

LEGEND: Neutrinoless Double-Beta Decay and Germanium Detector Technology, (STFC), PI: Prof David Waters, £23,840

AIDA 2020 Advanced European Infrastructures for Detectors and Accelerators, (European Commission), PI: Prof Matthew Wing, £301,108

AWAKE: a proton-driven plasma wakefield acceleration experiment at CERN, (STFC), PI: Prof Matthew Wing, £378,915

Search for Dark Protons and Investigation of QCD Using Novel Accelerator Scheme, (Leverhulme Trust), PI: Prof Matthew Wing, £318,272

Biophysics (BioP)

Several BioP grants are held through the London Centre for Nanotechnology (LCN).

New Approaches to Studying Redox Metabolism Using Time-Resolved NAD(P)H Fluorescence and Anisotropy, (BBSRC), PI: Prof Angus Bain, £296,382

Physics of bacterial growth control and antibiotic resistance, (EPSRC), PI: Dr Shiladitya Banerjee, £216,297

Physical determinants of cellular fitness for survival and proliferation, (Royal Society), PI: Dr Shiladitya Banerjee, £89,023

Molecular Control of Cortical Homeostasis and Cell Polarization, (Human Frontier Science Program), PI: Dr Shiladitya Banerjee, £241,241

Physics of cytoskeletal organisation and cellular morphogenesis, (Royal Society), PI: Dr Shiladitya Banerjee, £323,858

Softcharge: Charge Carrier Transport in Soft Matter: From Fundamentals to High-Performance Materials, (European Commission), PI: Prof Jochen Blumberger, £1,617,175

Advancing first principles computational modelling of electron transfer processes at molecule/electrode interfaces, (Pacific Northwest National Laboratory), PI: Prof Jochen Blumberger, £6,034

Direct probing of molecular interactions relevant to virus entry via force spectroscopy with optical tweezers in live cells, (EPSRC), PI: Dr Isabel Llorente Garcia, £91,041

Magnetic Nanoparticle Engineering Via Microreaction Technology, (EPSRC), PI: Prof Thanh Nguyen, £403,869

Advanced Flow Technology for Healthcare Materials Manufacturing, (EPSRC), PI: Prof Thanh Nguyen, £324,223

Nanoscale Magnetism of Novel Structures, (Air Force Office of Scientific Research), PI: Prof Thanh Nguyen, £110,345

Revealing unambiguous signatures of quantum coherence in photosynthetic complexes on a photonic chip, (Gordon and Betty Moore Foundation), PI: Prof Alexandra Olaya-Castro, £493,406

Collagen assembly: from molecules to fibrils, (EPSRC), PI: Dr Andela Saric, £100,772

Amyloid aggregation: Inhibition of self-replication and membrane-mediated control, (Academy of Medical Sciences), PI: Dr Andela Saric, £99,304

Rational design of cell-reshaping elements, (Royal Society), PI: Dr Andela Saric, £88,992

Physical mechanisms of membrane remodelling by active elastic filaments, (Royal Society), PI: Dr Andela Saric, £97,048

Physics of protein organisation beyond the cell's edge, (Royal Society), PI: Dr Andela Saric, £526,770

The Evolution Of Trafficking: From Archaea To Eukaryotes, (Volkswagen Stiftung), PI: Dr Andela Saric, £158,560

Non-Equilibrium Protein Assembly: from Building Blocks to Biological Machines, (European Commission), PI: Dr Andela Saric, £1,139,659

Supernemo Commissioning and Sensitivity Demonstration, (STFC), PI: Prof David Waters, £420,768

AIDA 2020 Advanced European Structure for Detectors and Accelerators, (European Commission H2020), PI: Prof Matthew Wing, £290,848

AWAKE: A Proton-Driven Plasma Wakefield Acceleration Experiment at CERN, (STFC), PI: Prof Matthew Wing, £179,279

Search for Dark Protons and Investigation of QCD Using Novel Accelerator Scheme, (Leverhulme Trust), PI: Prof Matthew Wing, £318,272

AWAKE: A Proton-Driven Plasma Wakefield Acceleration Experiment at CERN, (STFC), PI: Prof Matthew Wing, £378,915

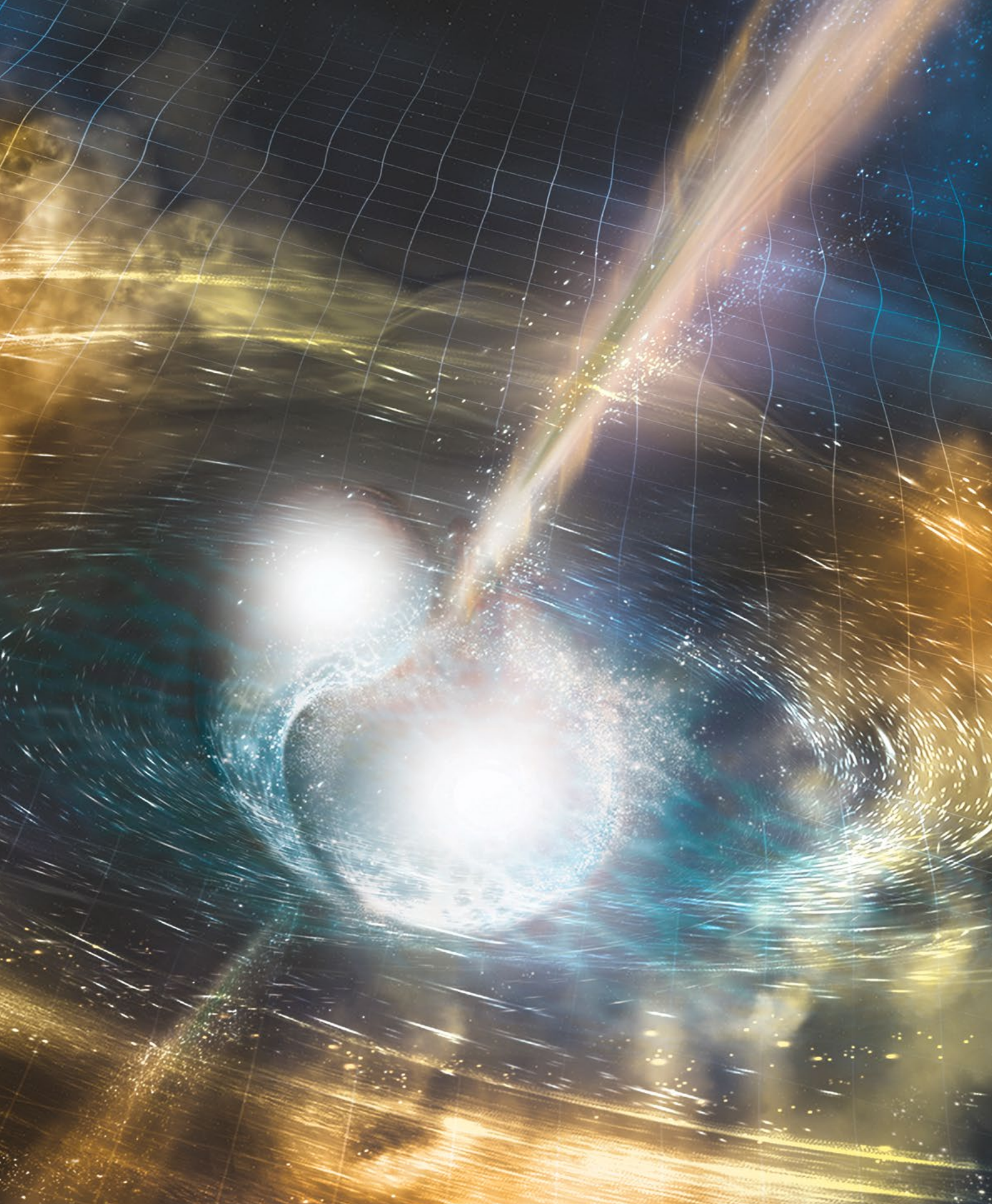

Staff Snapshot

Staff Snapshot

Head of Department Professor R. K. Prinja

Deputy Head of Department Professor F. Renzoni

Astrophysics

Head of Group:

Professor S. Viti (to May 2020), Professor G. Tinetti (from June 2020)

Professors:

G. Savini, N. Achilleos, M. J. Barlow, A. P. Doel, R. Ellis, J. Farihi, O. Lahav, H. Peiris, A. Pontzen, R. K. Prinja, J. M. C. Rawlings, A. Saintonge, G. Tinetti, S. Viti, S. Yurchenko

Associate Professors:

F. Abdalla, A. L. Aruliah, B. Joachimi, A. Pontzen, I. Waldmann

Lecturers:

S. Feeney, T. Greve, M. Kama, J. Sanders

Research Fellowships:

A. Da Mota Loureiro

Senior Research Fellows:

D. Brooks, F. Diego, J. Yates

Research Fellows:

A. Bevan, J. Bhatt, S. Bosman, C. Cadiou, C. Circosta, W. Dunn, B. Edwards, J. Guo, Y. Ito, N. Jeffrey, F. Kirchschrager, A. Mancini, D. Millas, N. Nikolaos, P. Portela, A. Saxena, S. Stopyra, M. Tessenyi, A. Tsiaras, R. Wesson, L. Whiteway, L. Whittaker

Marie Curie Early Stage Researchers:

R. O'Donoghue, M. Keil

Support Staff:

S. Boyle, J. Deacon, E. Dunford, E. Edmondson, J. Fabbri, S. Fossey, C. Jenner, A. Maguire, R. Martin, M. Pearson, K. Nakum, M. Rangrej, T. Schlichter, S. Sullivan

Atomic, Molecular, Optical and Positron Physics

Head of Group:

Professor S. Hogan

Professors:

A. Bain, P. Barker, S. Bose, D. Browne, D. Cassidy, A. Emmanouilidou, C. Figueira de Morisson Faria, S. Hogan, G. Laricchia, T. Monteiro, A. Olaya-Castro, J. Oppenheim, F. Renzoni, A. Serafini, M. Szymanska, J. Tennyson, S. Yurchenko

Associate Professor:

I. Lorente Garcia

Research Fellowships:

N. Breuckmann, J. Lang, Y.L. Li, L. Masanes, A. Maxwell, J. Palmer, S. Qvarfort, C. Sparaciari, A. Vigilante

Research Fellows:

T. Babij, T. Blacker, S. Brawley, S. Burton, B. Cooper, G. Dagvadorj, C. Deans, L. Lao, C. Nation, O. Polyansky, A. Pontin, A. Rahman, E. Spinlove, D. Toniolo, M. Toros

Support Staff:

J. Dumper, F. Garza, C. Godden, F. R. Jawad, S. Thomas

Biological Physics

Heads of Group:

Professor B. Hoogenboom

Professors:

A. Bain (also AMOPP), B. Baum (MRC LMCB), J. Blumberger (also CMMP), G. Charras (Cell & Developmental Biology), B. Hoogenboom, P. Jones, T. Nguyen, A. Olaya-Castro (also AMOPP), I. Robinson (also CMMP)

Associate Professor:

I. Lorente Garcia (also AMOPP), A. Saric

Senior Research Fellows:

G. Salbreux (Crick), M. Molodtsov (Crick)

Senior Research Associate:

T. Le

Research Fellows:

C. Bortolini, L. Chu, X. Jiang, J. Krausser, N. Ojic, I. Palaia, G. Pobegalov, T. Smart, T. Trakoolwilaiwan, X. Wu

Support Staff:

J. Gill-Thind

Condensed Matter and Materials Physics

Head of Group:

Professor S. T. Bramwell

Professors:

J. Blumberger, D. Bowler, S. Bramwell, F. Cacialli, A. Fisher, I. Ford, A. Green, C. Hirjibehedin, C. Howard, D. McMorro, A. Michaelides, I. Robinson, A. Shluger, N. Skipper, M. Szymanska

Associate Professors and Readers:

M. Buitelaar, F. Kruger, E. Rosta, P. Zubko

Senior Lecturer:

S. Zochowski

Lecturers:

R. Johnson, A. Pal, S. Schofield

Research Fellowships:

C. Pruteanu, A. Seel

Research Fellows:

S. Azadi, R. Darkins, Z. Futera, P. Gasparotto, S. Ghosh, T. Gill, T. Greenland, L. Ishibe Veiga, A. James, C. Kumarasinghe, K. Kwakwa, A. Minotto, E. Parsons, C. Penschke, A. Pyne, M. Righetto, M. Szyniszewski, J. Vale, B. Villis, C. Yin, A. Zen, O. Ziogou

Most Research staff are employed through the LCN

Support Staff:

A. Gormanly, J. Levin, D. Ottley, S. Patel, F. Sidoli, K. Stoneham, J. Walden

High Energy Physics

Head of Group:

Professor R. Saakyan

Professors:

J. M. Butterworth, M. Campanelli, F. Deppisch, C. Ghag, N. Konstantinidis, R. Nichol, E. Nurse, R. Saakyan, J. A. Thomas, R. S. Thorne, D. Waters, M. Wing

Associate Professors:

K. Hamilton, G. Hesketh, S. Jolly, A. Korn, T. Scanlon

Lecturer:

R. Chislett

Principal and Senior Research Associates:

R. Flack, P. Sherwood, B. Waugh

Ernst Rutherford Fellows:

M. Agostini, J. Dobson

Royal Society University Research Fellows:

C. Backhouse

Research Fellows:

J. Cesar, D. Cooke, L. Corpe, L. Cremonesi, T. Cridge, Z. Grout, C. Gutschow, A. Hartin, A. Holin, N. Kimura, A. Martyniuk, V. Monachello, C. Patrick, R. Radogna, A. Sztuc, T. Fruth

Support Staff:

D. Attree, A. Basharina-Freshville, G. Crone, E. Edmondson, C. Godden, T. Hoare, E. Motuk, S. Thomas, M. Warren

Teaching

Director of Undergraduate Teaching:
Professor N. Skipper

Director of Postgraduate Studies:
S. Zochowski

Undergraduate Careers Officer:
J. Farihi

Director of Laboratories:
D. Cassidy

Professorial Teaching Fellow:
P. Bartlett

Principal Teaching Fellows:
D. Armoogum, E. Bailey, L. Dash, N. Nicolaou

Senior Teaching Fellows:
J. Bhamrah, F. Diego Quintana, S. Fossey

Teaching Fellow:
S. Boyle

Laboratory Superintendent:
D. Thomas

Laboratory Technicians:
B. T. Bristol, M. A. Sterling

Experimental Development Officer:
K. Vine

Admissions Tutors:
A. Aruliah (MSc), F. Diego (Astronomy Certificate),
J. Blumberger (Postgraduate Research),
P. Jones (Undergraduate)

Schools Liaison Officer:
C. Howard

Programme Tutors:
D. Armoogum (Physics and Astronomy),
S. Fossey (MSc), N. Nicolaou (Physics and Astronomy),
J. C. Rawlings (Astronomy Certificate),
S. Zochowski (PhD)

UCL Observatory

Director:
G. Savini

Senior Observatory Technicians:
M. Pearson (Mechanical and site officer)
T. Schlichter (Computing and Instrumentation Officer)

Maps Workshop

Superintendent:
D. Cassidy

Professional Services

Departmental Manager:
L. Coletti Campbell

Senior Staffing and Communications Officer:
B. Carboo

Grants Officer:
Currently recruiting

Accounts Officer:
K. Coleman

Education Support Team

Senior Postgraduate and Student Finance Administrator:
N. Waller

Senior Teaching and Learning Administrator:
S. Lovell

MSc Teaching and Learning Administrator:
S. Begum, S. Murphy

UG Teaching and Learning Administrators:
H. Copeland, R Edmonds

Astrophysics Research Group and Observatory (UCLO) Administrator:
K. Nakum

AMOPP/HEP Research Groups & Goods Inwards Administrator:
S. Thomas

Biological Physics (BioP) Research Group Administrator:
J. Gill-Thind

Finance and Research Group Administrator (CMMP):
J. Levin

Operations Administrator (Centre for Space Exoplanet Data):
E. Dunford

Computing Administrator (HEP):
T. Hoare

IT Systems Manager:
F. Garza (AMOPP & BioP), F. Ihsan (Teaching and Learning)

Safety Officer and Estates Manager:
L. Bebbington

Outreach and Public Engagement

Outreach Coordinator and Ogden Science Officer:
M. Fuller

Science Centre Organiser:
S. Kadifachi

Doctoral Training Centre

CDT Manager, CDT in Data Intensive Science (DIS):
M. Witcombe

Visiting Professors, Honorary Professors and Emeritus Staff:

A. Aylward, S. Bridle, R. Cohen, M. Coupland, D. H. Davis, J. Drew,
M. M. Dworetzky, M. Duff, M. Ellerby, J. Ellis, M. Esten, I. Ferreras,
J. L. Finney, F. Fernandez-Alonso, J. Fordham, T. Fountain, I. Furniss,
M. J. Gillan, P. Guio, A. H. Harker, B. Hiley, C. Hilsum, P. Hobson,
I. D. Howarth, J. W. Humberston, T. W. Jones, N. Kaiser, A. Kravtsov,
B. R. Martin, G. Materlik, K. A. McEwen, J. McKenzie, D. J. Miller,
S. Miller, D. Moores, R. Maiolino, W. Newell, G. Peach, H. Saraph,
A. Slosar, A. C. Smith, W. B. Somerville, P. J. Storey, D. N. Tovee,
C. Wilkin, D. A. Williams

